



Model IRB

LOW INTENSITY TUBE TYPE INFRARED RESIDENTIAL GARAGE/WORKSHOP HEATER

INSTALLATION / OWNER'S MANUAL



WARNING Improper installation, adjustment, alteration, service or maintenance can cause property damage, injury or death.
Read the installation and operating and maintenance instructions thoroughly before installing or servicing this equipment.

SAFETY ALERT:



This heater must be installed and serviced only by a trained gas service technician. Failure to comply could result in personal injury, death, fire and/or property damage.

Do not store or use gasoline or other flammable vapours and liquids in the vicinity of this or any other gas fired appliance.



IF YOU SMELL GAS:

- Extinguish any open flame
- Do not attempt to light this or any other appliance
- Don't touch any electrical switch, or telephone
- Immediately call your gas supplier from a neighbor's phone
- Follow any and all instruction from your gas supplier
- If your gas supplier is not available, call the fire department



FIELD CONVERTIBILITY:
This appliance is field convertible to LP gas.

Keep this manual in a secure place .
Record for future reference:

Model #: _____

Serial #: _____

(located on heater rating label)



NOTICE:

This manual is current for this product. Occasional revision of the product Certification Standard may require changes to the product and/or this manual.

This publication, or parts thereof, may not be reproduced in any form, without prior written consent from The Manufacturer. Unauthorized use or distribution of this publication is strictly prohibited.

Schwank Group

Schwank and InfraSave brands

5285 Bradco Boulevard

Mississauga, Ontario, L4W 2A6

PO Box 988, 2 Schwank Way

Waynesboro, Georgia 30830

Customer & Technical Services

Phone: 877-446-3727

Fax: 866-361-0523

e-mail: csr@schwankgroup.com

www.schwankgroup.com

www.infrasave.com

IRB SERIES GAS FIRED INFRARED LOW INTENSITY TUBE TYPE

TABLE OF CONTENTS

| TOPIC | PAGE | TOPIC |PAGE |
|--|------------|---|-----------|
| <u>INSTALLATION</u> | | | |
| <u>IMPORTANT INFORMATION - READ FIRST</u> | | | |
| APPLICATION | 4 | 13. GAS SUPPLY | 26 |
| HEATER EXPANSION | 5, 31 | HEATER EXPANSION | 27 |
| GAS CONNECTION | 5, 31 | FLEXIBLE GAS CONNECTION | 27 |
| See also "Flexible Gas Connection" | 31 | 14. ELECTRICAL AND THERMOSTAT | 29 |
| VENTING | 5, 26 | 15. HIGH ALTITUDE INSTALLATION..... | 29 |
| START UP 'SMOKE' | 5 | 16. LIGHTING INSTRUCTIONS | 29 |
| CLEARANCE TO COMBUSTIBLES | 6 | 17. RECOMMENDED MAINTENANCE | 29 |
| Clearances Figure & Table..... | 7 | 18. WIRING DIAGRAMS | |
| STACKING HEIGHT SIGN | 8 | LINE VOLTAGE THERMOSTAT..... | 30 |
| 1. LABOR REQUIREMENTS..... | 9 | 24 VOLT THERMOSTAT | 31 |
| 2. INSTALLATION IN AIRCRAFT HANGARS..... | 9 | 19. WIRING DIAGRAM MULTIPLE HEATERS PER THERMOSTAT | 32 |
| 3. INSTALLATION IN COMMERCIAL GARAGES | 9 | 20. SEQUENCE OF OPERATION | 33 |
| 4. INSTALLATIONS OTHER THAN SPACE HEATING | 9 | 21. TROUBLESHOOTING GUIDE | 34 |
| 5. PRE-INSTALLATION SURVEY | 10 | 22. SPARK IGNITION CIRCUIT | 36 |
| 6. MOUNTING CLEARANCES | 11 | SPARK IGNITER SET UP | 36 |
| SERVICE CLEARANCE | 11 | 23. FLAME SENSING CIRCUIT | 37 |
| HEATER PLACEMENT GUIDELINES | 12 | 24. START- UP / COMMISSIONING SHEET..... | 38 |
| 7. SYSTEMS WITH 90° & 180° ELBOWS..... | 12 | <u>PRODUCT DIMENSIONS & DATA</u> | |
| ELBOW KIT DIMENSIONS | 13, 50 | 25. HEATER DIMENSIONS / WEIGHTS | 40 |
| 8. SUSPENDING THE SYSTEM | 14 | INSTALLATION DIMENSIONS | 41 |
| 9. BURNER & TUBE INSTALLATION | | 26. BURNER / TUBE KIT ASSEMBLY CHART | |
| STRAIGHT TUBE SYSTEM | 15 | STRAIGHT & 'U' TUBE SYSTEMS | 42 |
| 'U' TUBE SYSTEM | 17 | 27. TURBULATORS | 43 |
| 10. REFLECTOR INSTALLATION..... | 19 | 28. HIGH ALTITUDE & ORIFICE CHART | 43 - 44 |
| 11. FLUE VENTING | 21 | 29. OPTIONAL ACCESSORIES..... | 46 - 48 |
| 12. COMBUSTION AIR DUCT..... | 24 | 30. BURNER PARTS LIST | 49 - 50 |
| | | 30. TUBE SYSTEM PARTS LIST | 51 |
| | | WARRANTY STATEMENT..... | BACK PAGE |



WARNING



Improper installation, adjustment, alteration, service or maintenance can cause property damage, injury or death. Read and understand this installation and operation manual thoroughly prior to assembly, installation, operation or service to this appliance.



This heater must be installed and serviced only by a trained gas service technician.

Do not store or use gasoline or other flammable vapours and liquids in the vicinity of this or any other gas fired appliance.



Failure to comply could result in personal injury, death, fire and/or property damage.

Do not store or use gasoline or other flammable vapours and liquids in the vicinity of this or any other gas fired appliance.

This appliance may have sharp edges and corners. Wear protective clothing such as gloves and protective eye wear when servicing this or any other appliance.

APPLICATION

A gas-fired radiant tube heater may be installed for heating of commercial / industrial non-residential spaces. It is beyond the scope of these instructions to consider all conditions that may be encountered. Installation must conform with all local building codes or, in the absence of local codes, with the National Fuel Gas Code, ANSI Z223.1/NFPA 54 in the U.S.A. or the Natural Gas and Propane Installation Code, CSA B149.1 in Canada. The latest edition Electrical Code ANSI/NFPA N0 70 in the U.S.A. and PART 1 CSA C22.1 in Canada must also be observed.

Installation of a gas fired tube heater must conform to all heating installation design procedures including clearance to combustibles, connection to the gas and electrical supplies, and ventilation.

This heater is not for installation in a Class 1 or Class 2 explosive environment, nor a residence. If installation of this equipment is in question, consult with local authorities having jurisdiction (Fire Marshall, labor department, insurance underwriter, or others).

Revisions to codes and/or standards, may require revision to equipment and installation procedures. In case of discrepancy, the latest codes, standards, and installation manual will take priority over prior releases.

Models IRB may be installed for heating of commercial / industrial non-residential **indoor spaces**.

MODELS AVAILABLE FOR OTHER APPLICATIONS:

Models SPW-JZ and IWP have a powder coated water resistant burner enclosure and may be installed for heating of commercial / industrial non-residential **outdoor spaces and wet indoor environments**.

Models STW-JZ and IW have a stainless steel water resistant burner enclosure and may be installed for heating of commercial / industrial non-residential **outdoor spaces and harsh wet indoor environments**.



WARNING

Heater Expansion



It is a normal condition that during heat-up and cool-down a tube heater will expand and contract. Allowances for heater expansion must be made in the gas connection, venting and combustion air ducting. Improper installation, alteration, or adjustment can result in



WARNING

Gas Connection



Improper installation, connection, or adjustment can result in property damage, toxic gases, asphyxiation, injury or death. Using an approved flexible gas connector in the USA or Type 1 hose connector in Canada, the gas supply to the heater must be connected and tested in accordance with all local, state, provincial, and national codes (ANSI Z223.1/NFPA 54 in USA; B149.1 in Canada) and as indicated in this manual. **Refer to Section 13**



WARNING

Venting



Inadequate venting of a heater may result in asphyxiation, carbon monoxide poisoning, injury or death. This heater may be directly or indirectly vented from the space. Venting must be in accordance with all local, state, provincial, and national codes (ANSI Z223.1/NFPA 54 in USA; B149.1 in Canada) and as indicated in this manual. **Refer to Sections 11 & 12**



WARNING

Start-Up 'SMOKE' Condition

During start up, the heating of material coatings used in the production process of tubes and reflectors will create smoke during the initial period of operation. This condition is normal and temporary .

Ensure that there is sufficient ventilation to adequately clear any smoke from the space.

Notify site and safety personnel to ensure that alarm systems are not unduly activated.



WARNING

Clearance to combustibles

Location of flammable or explosive objects, liquids or vapors close to the heater may cause fire or explosion and result in property damage, injury or death. Do not use, store or locate flammable or explosive objects, liquids or vapors in proximity of the heater.



The clearance to combustible material represents the minimum distance that must be maintained between the outer heater surface and a nearby surface. The stated clearance to combustibles represents a surface temperature of 90F° (50C°) above room temperature. It is the installer's responsibility to ensure that building materials with a low heat tolerance which may degrade at lower temperatures are protected to prevent degradation.

In locations used for the storage of combustible materials, signs must be posted to specify the maximum permissible stacking height to maintain the required clearances from the heater to the combustibles. Such signs must either be posted adjacent to the heater thermostats or in the absence of such thermostats in a conspicuous location. In addition to stored or stationary material, consideration must also be given to moveable objects such as cranes, vehicles, and overhead doors, and structural objects such as sprinkler heads, electrical and gas lines, and electrical fixtures.

It is beyond the scope of these instructions to consider all conditions that may be encountered. Consult local authorities such as the Fire Marshall, insurance carrier, or safety authorities if you are uncertain as to the safety or applicability of the proposed installation.

Refer to Figure 1 and Table 1 for the certified clearances to combustibles for the appropriate model input/size.

FIGURE 1 MINIMUM CLEARANCES TO COMBUSTIBLES* - refer to Table 1 for values

NOTE: A 'PEEL & STICK' SIGN IS SUPPLIED: USE AN INDELIBLE MARKER TO ENTER VALUES 'H', 'S', 'F', & 'B' ON .
 POST THE SIGN ADJACENT TO THE HEATER THERMOSTAT OR IN A PROMINENT LOCATION. See next page for details.

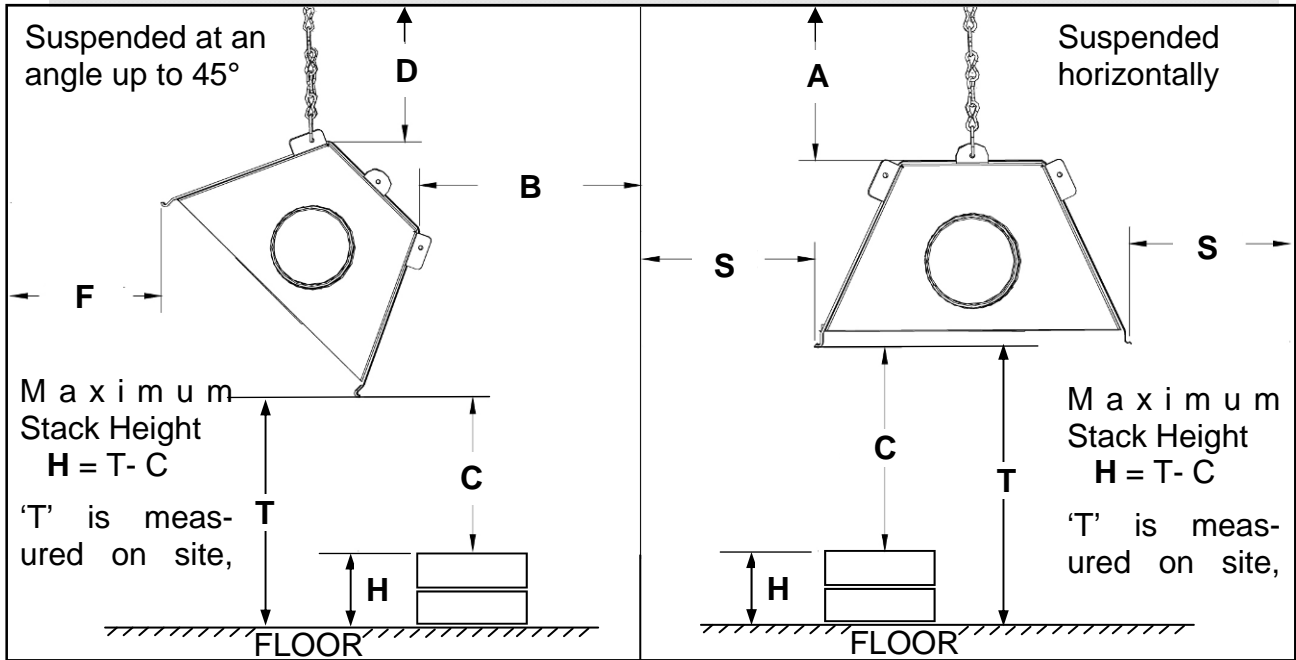

TABLE 1 MINIMUM CLEARANCES TO COMBUSTIBLES*

| MODEL | HORIZONTAL | | | ANGLE UP TO 45 DEGREES | | | |
|----------------------------|-------------|-------------|-------------|------------------------|-------------|-------------|-------------|
| | TOP | SIDE | BELOW | TOP | REAR | FRONT | BELOW |
| | A | S | C | D | B | F | C |
| Both "Straight" & "U-Tube" | inches (cm) | inches (cm) | inches (cm) | inches (cm) | inches (cm) | inches (cm) | inches (cm) |
| IRB 60 | 2.5" (6) | 5.5" (14) | 34" (86) | 3" (8) | 1" (2.5) | 17" (43) | 34" (86) |
| IRB 45 | 4.5" (11) | 8.5" (22) | 32" (81) | 5" (13) | 1" (2.5) | 29" (74) | 32" (81) |

***NOTE: Clearances are measured from the reflector.**

The clearance to combustible materials represents the minimum distance that must be maintained between the heater and a nearby surface. **The stated clearance to combustibles represents a surface temperature of 90F° (50C°) above room temperature.** continued ...

It is the installer's responsibility to ensure that building materials with a low heat tolerance which may degrade at lower temperatures are protected to prevent degradation.

VENT END CLEARANCE: Clearances from the vent pipe are determined by local or national installation codes, but must not be less than 6 inches (15 cm). For 'unvented' installation, a minimum distance of 24 inches (61 cm) is required from the end of heater to a combustible surface.



WARNING In locations used for the storage of combustible materials: **Signs must be posted** specifying the *maximum permissible stacking height* to maintain the required clearances from the heater to the combustibles.

The signs must be posted either adjacent to the IR heating system thermostats or in the absence of such thermostats, in a conspicuous place.

For your convenience a "peel and stick" sign is provided with this heater. Use a permanent marker to record the required dimensions on the sign.

To calculate the value 'H': $(H = T - C)$

- Measure the on site distance between bottom of the heater and the floor = 'T' inches (cm).
- Refer to Table 1 to get the value 'C' that corresponds to the model you are installing
- Subtract the clearance below the heater 'C' from 'T' to get value 'H'.
- Enter this value 'H' on the sign.

Refer to the information for the heater model being installed in Figure 1 and Table 1 to get the values for dimensions 'S', 'F' and 'B'.

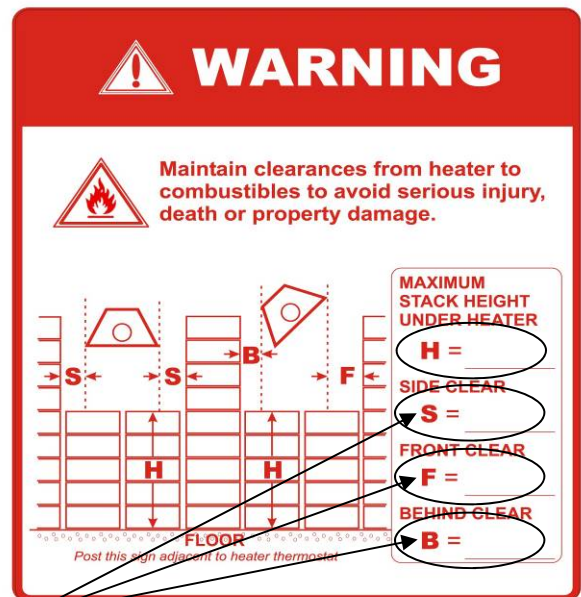

Post this sign as instructed above.

1. LABOR REQUIREMENTS

Two persons are required to safely install this equipment. Wear gloves and other required safety protection.

2. INSTALLATION IN COMMERCIAL AIRCRAFT HANGARS

Low intensity radiant tube heaters are suitable for use in aircraft hangars when installed in accordance with the latest edition of the Standard for *Aircraft Hangars*, ANSI/NFPA No 409 in the USA, or the Canadian *Natural Gas and Propane Installation Code*, B149.1.

- A. A minimum clearance of 10 ft (3 m) above either the highest fuel storage compartment or the highest engine enclosure of the highest aircraft which may occupy the hangar. The clearance to the bottom of the heater shall be measured from the upper surface of either the fuel storage compartment or the engine enclosure, whichever is higher from the floor.
- B. A minimum clearance of 8 ft (2.4 m) must be maintained from the bottom of the heater to the floor in other sections of the aircraft hangar, such as offices and shops, which communicate with areas for servicing or storage. Refer to Section 1 for proper mounting clearances to combustibles.
- C. Heaters must be located so as to be protected from damage by aircraft and other objects, such as cranes and movable scaffolding.
- D. Heaters must be located so as to be accessible for servicing and adjustment.

3. INSTALLATION IN COMMERCIAL GARAGES AND PARKING STRUCTURES

Low Intensity Heaters are suitable for use in commercial garages when installed in accordance with the latest edition of the Standard for *Parking Structures*, ANSI/NFPA 88A, or the Standard for *Repair Garages*, ANSI/NFPA No. 88B, or the Canadian *Natural Gas and Propane Installation Code*, B149.1.



WARNING

An overhead heater shall be located high enough to maintain the minimum distance to combustibles, as shown on the heater rating plate, from the heater to any vehicles parked below the heater.

Overhead heaters shall be installed at least 8 ft (2.4 m) above the floor.

4. INSTALLATIONS OTHER THAN SPACE HEATING

Use for process or other applications that are not space heating will void the C.S.A. certification and product warranty. Process application requires field inspection and/or certification by local authorities having jurisdiction.



WARNING



Improper installation, adjustment, alteration, service or maintenance can cause property damage, injury or death. Read and understand this installation and operation manual thoroughly prior to assembly, installation, operation or service to this appliance.



This heater must be installed and serviced only by a trained gas service technician. Do not store or use gasoline or other flammable vapours and liquids in the vicinity of this or any other gas fired appliance.



Failure to comply could result in personal injury, death, fire and/or property damage. Do not store or use gasoline or other flammable vapours and liquids in the vicinity of this or any other gas fired appliance.

5. PRE INSTALLATION SURVEY

It is recommended that a full heating design including heat loss calculation be conducted on the structure or area to be heated. Heater sizing and placement must consider available mounting height, sources of greatest heat loss, and the certified clearances to combustibles with respect to stored material, moveable objects (cranes, vehicles, lifts, overhead doors, etc), sprinkler system heads, and other obstructions on the site. Consideration must also be given to vent / duct placement and the allowable combined lengths of vent and duct. Carefully survey the area to be heated, and for best results place burner and combustion chamber in the coldest area(s) .

Installation must conform with all local, state, provincial and national code requirements including the current latest edition ANSI Z223.1 (NFPA 54) in the U.S.A. and B149.1 installation code in Canada, for gas burning appliances and equipment. The latest edition Electrical Code ANSI/NFPA N0 70 in the U.S.A. and PART 1 CSA C22.1 in Canada must also be observed.

The heating system must have gas piping of the correct diameter, length, and arrangement to function properly. For this reason, a layout drawing is necessary.

6. MOUNTING CLEARANCES

This heater must be mounted with at least the minimum clearances between the heater and combustibles as shown in FIG-1, TABLE 1, Page 7. It is the installer's responsibility to ensure that building materials with a low heat tolerance which may degrade at lower temperatures are protected to prevent degradation.

Positioning of lights, sprinkler heads, overhead doors, storage areas, gas and electrical lines, parked vehicles, cranes and any other possible obstruction or hazard must be evaluated prior to installation.

Ensure adequate clearance around the air intake at the burner to allow sufficient combustion air supply to the heater.

6A. SERVICE CLEARANCE: The lower 'jaw' of the burner cabinet swings down to provide convenient service access to burner components. Provide a minimum clearance from any wall or obstruction of 6 inches (15 cm) to the access end of the burner housing, and a minimum of 24 inches (61 cm) to any ONE side to allow servicing of burner, blower and controls. (see Figure 2 below) - the minimum clearances to combustibles must always be maintained.

For guidelines to heater placement refer to TABLE 2 (next page).

FIGURE 2

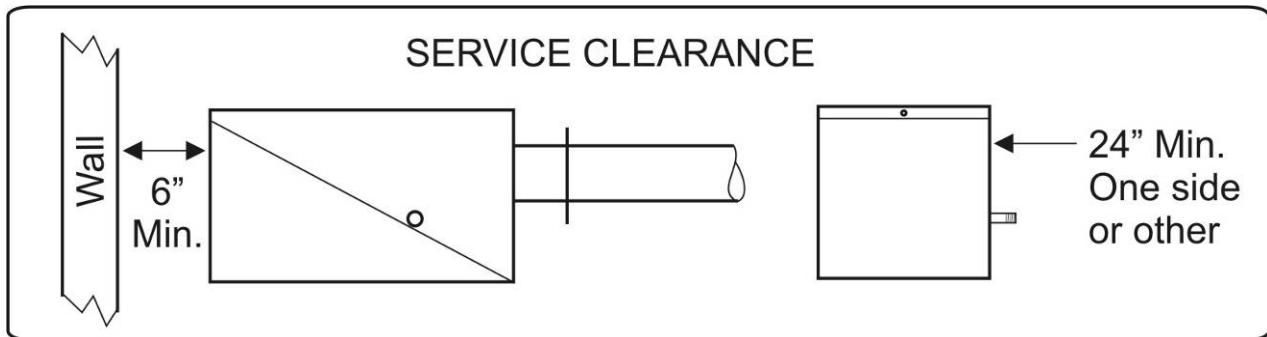



TABLE 2: GUIDELINES FOR HEATER PLACEMENT

| MODEL “Straight” or “U-Tube” | MOUNTING HEIGHT ft (m) | MAXIMUM DISTANCE BETWEEN HEATERS ft (m) | DISTANCE – OUTSIDE WALL TO HEATER LONG AXIS (PARALLEL TO WALL) IN “FEET” | |
|------------------------------------|------------------------------|---|--|--|
| | | | HORIZONTAL ft (m) | ANGLE |
| IRB 60 | 8 – 14 (2.5 - 5) | 25 (8) | 11 – 15 (3.4 - 5) | COMBUSTIBLE CLEARANCE BEHIND (refer to Table 1) |
| IRB 45 | 8 – 12 (2.5 - 4) | 20 (6) | 8 – 12 (2.5 - 4) | |

* RECOMMENDED MOUNTING HEIGHTS are typical to provide optimum comfort in general space heating applications. Variance to these typical heights can occur in some applications:

- Higher mounting heights due to structure or application requirements
- Lower mounting heights for area or ‘spot’ heat, or in areas with greater infiltration losses (near overhead doors, etc)



IMPORTANT: Single or multiple heater placement must be such that continuous operation of heater(s) will not cause combustible material or materials in storage to reach a temperature in excess of ambient temperature plus 90F° (50C°).

It is the installer’s responsibility to ensure that building materials with a low heat tolerance which may degrade at lower temperatures are protected to prevent degradation.

Refer to “Clearance to Combustibles” information on pages 6 to 8, and Figure 1 and Table 1.

7. SYSTEMS INCORPORATING 90° ELBOWS AND 180° ELBOWS

The radiant tube heater can be installed in configurations as illustrated in FIGURE 4. (next page) with a maximum of two 90° elbows per heater. The use of elbows reduces the total maximum vent allowable. (See Section 11 : Flue venting)

90° elbows (JS-0528-SM) are shipped as a kit with one coupler, and two reflector end caps.

The IRB is available in a “U-Tube” model - IRBU - using a 180° turn box. A double wide reflector

tor covers the double tube run. Alternately, for a 180° elbow, order 2 x 90° kits that connect to create a 180°.



IMPORTANT: Elbow Location / Input: A minimum run of straight radiant tube must be connected to the burner before any elbow as follows: Inputs 60 Mbh (18 kW), and 45 Mbh (13 kW) a minimum of 10 ft (3 m) straight tube before elbow.

FIGURE 3 SYSTEM ELBOW KIT - see page 50 for 180° elbow dimensions

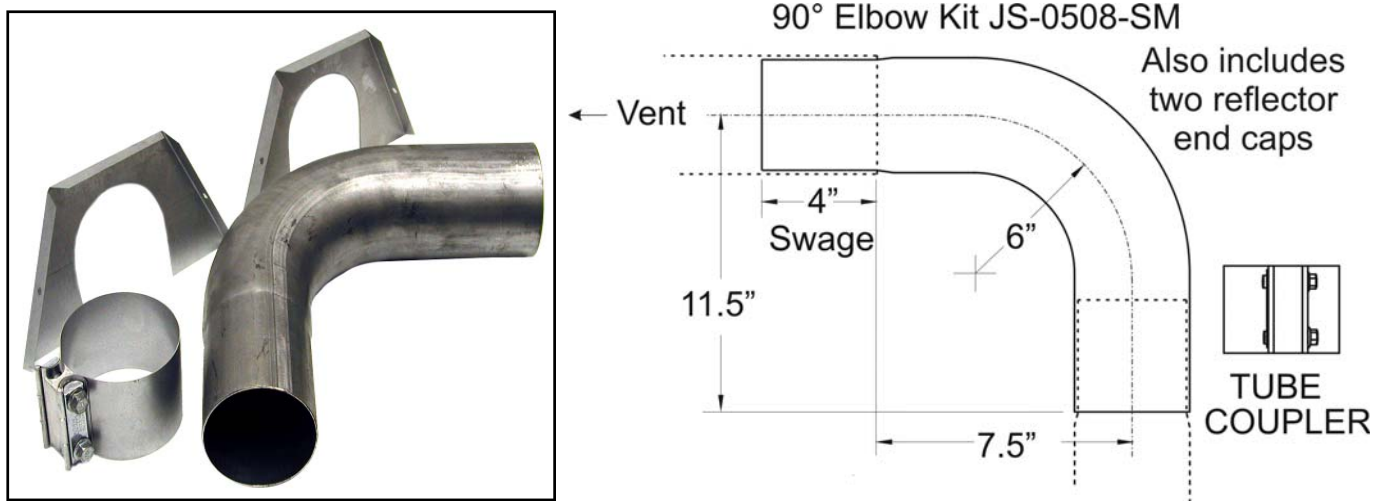
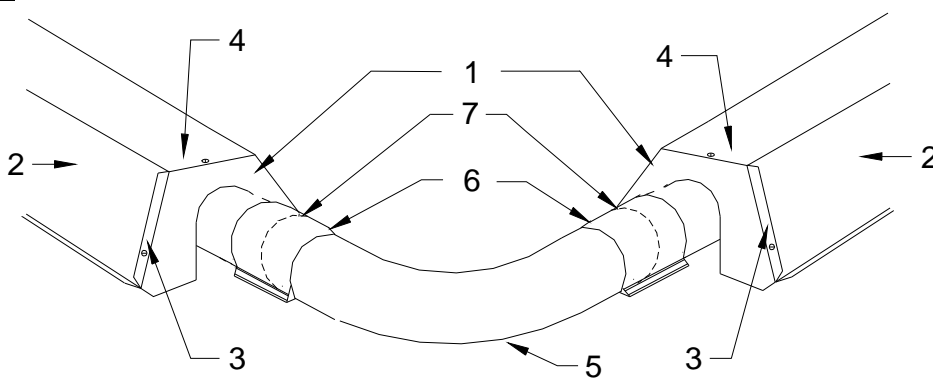

FIGURE 4 90° ELBOW INSTALLATION



- | | |
|---|--|
| 1 End-Cap | 5 90° Elbow |
| 2 Reflector | 6 Tube Coupler |
| 3 End Cap Flange <u>OVER</u> Reflector | 7 Unswaged end of elbow and tube (swage of previous tube or elbow inserted). |
| 4 End Cap Flange <u>UNDER</u> Reflector | |

8. SUSPENDING THE SYSTEM - GENERAL



Inadequate or improper suspension of the tube heater can result in collapse of the system, property damage, and personal injury or death.

It is the installer's responsibility to ensure that the hardware and structural supports from which the heater is suspended are sound and of adequate strength to support the weight and expansion forces of the heater.

Consider that the heater will expand in length as much as 1/2 inch (12.5 mm) or more for every 10 ft (3 m) of system length – typically the greater the firing rate, the greater the expansion.

Refer to Sections 13 & 14

- 1) Survey the available structural supports, considering the system configuration and heat requirements of the area to establish the optimum heater location.
 - a) Locating a heater directly under joists or beams, or installing supplemental steel support rail or angle iron can substantially reduce labor and materials
- 2) Hardware with a minimum 60 lb. (30 kg) work load must be used at each heater suspension point. A #8 Jack Chain or equivalent is typically used for suspending the heater.
 - a) Connect to the structure using typical hardware as illustrated in FIGURE 6 (below) or by other mechanically sound means
 - b) If rigid devices such as 3/8" threaded rods are used for suspension, swing joints or other means must be provided to allow for system expansion - approximately 1/2 inch to 1 inch for every 10 ft (1 cm to 2.5 cm for every 3 m) of system length.
- 3) Tube system hangers must be located:

i: Straight in line

ii: At a common height (level)

NOTE: It is important that the tubes in the system are installed in alignment horizontally (level) and vertically (in line) – this will ensure system integrity

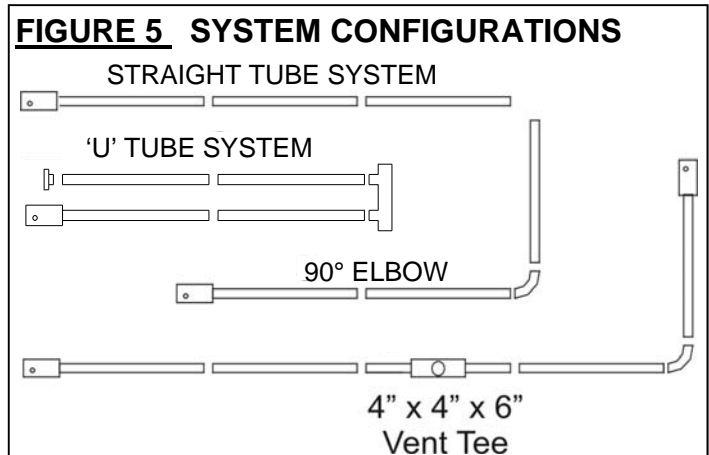
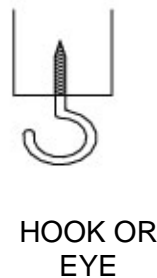
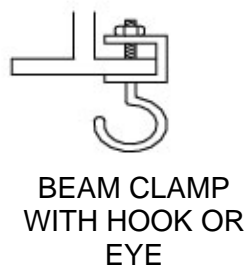
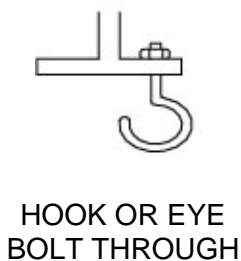

FIGURE 6 TYPICAL MOUNTING HARDWARE



NOTE: It is the installer's responsibility to ensure that mounting hardware and fastening to structure are of sufficient strength to support the system.

9 INSTALLATION OF HANGERS, TUBES AND BURNER

9.1 IRB STRAIGHT TUBE SYSTEM ~ BURNER AND TUBE INSTALLATION

Note: Turbulators are ALWAYS installed at the vent end of the heater .

1) Install Hangers:

- i: No closer than 3" (5 CM) and no further than 5" (10 cm) from the burner/tube flange
- ii: No closer than 6" (15 cm) either side of a tube connection in the system
- iii: No further than 24" (61 cm) either side of a tube connection in the system

2) With all hangers in alignment and suspended at the same height, insert first aluminized tube section, through 4" hole into first two wire hangers.

NOTE: INSTALL THE FIRST AND SECOND TUBES (FROM BURNER END) WITH THE WELDED SEAM ALONG THE TUBE LENGTH FACING DOWNWARD

3) Bolt burner to flange on first tube section, SEE FIGURE 8.

4) Slide a Torctite tube coupler over the swaged end of the first tube, then join the second tube over the swage in the first tube

5) Slide the Torctite coupler into position across the center of the joint - SEE FIGURE 9

6) IMPORTANT: TOURQUE THE COUPLER BOLTS TO 40 ft-lbs

7) Subsequent lengths of tube can then be installed, by joining them together swaged portion inside the next tube and locking the joints using the Torctite coupler. SEE FIGURE 9.

8) If there is a 90° elbow in the system refer to Section 7 and Figures 3 & 4

FIGURE 7 STRAIGHT TUBE TYPICAL HANGER & SUPPORT SPACINGS

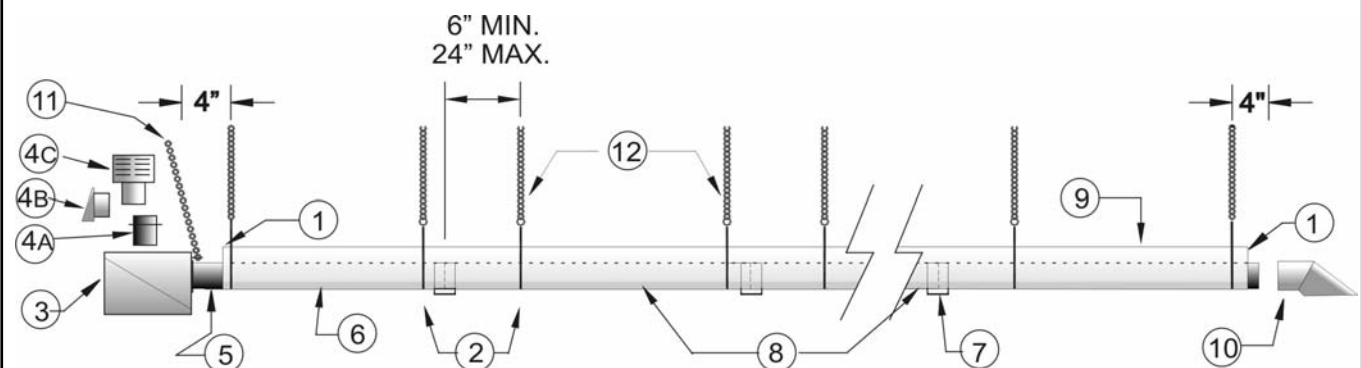

SUSPEND ALL TUBES BY TWO (2) HANGERS PER 10' LENGTH, LOCATED BETWEEN 6" to 24" FROM EACH TUBE CONNECTION.

INSTALL FIRST AND SECOND TUBES (FROM BURNER END) WITH WELDED SEAM FACING DOWNWARD.

- | | | |
|-----------------------------|-----------------------------|---------------------------|
| 1 - END CAP | 4B - JS-0532-VC 4" WALL CAP | 8 - STEEL TUBE(S) |
| 2 - WIRE HANGER | 4C - JA-0528-XX 4" ROOF CAP | 9 - REFLECTOR |
| 3 - BURNER ASSEMBLY | 5 - SIGHT GLASS | 10 - FLUE VENT TERMINAL |
| 4 - COMBUSTION AIR OPTIONS: | 6 - ALUMINIZED TUBE WITH | 11 - BURNER SUPPORT CHAIN |
| 4A - JS-0532-SE 4" INTAKE | FLANGE | 12 - HANGER SUPPORT |
| ADAPTER | 7 - TORCTITE TUBE COUPLER | CHAINS |

FIGURE 8
BOLTING BURNER TO FLANGED TUBE

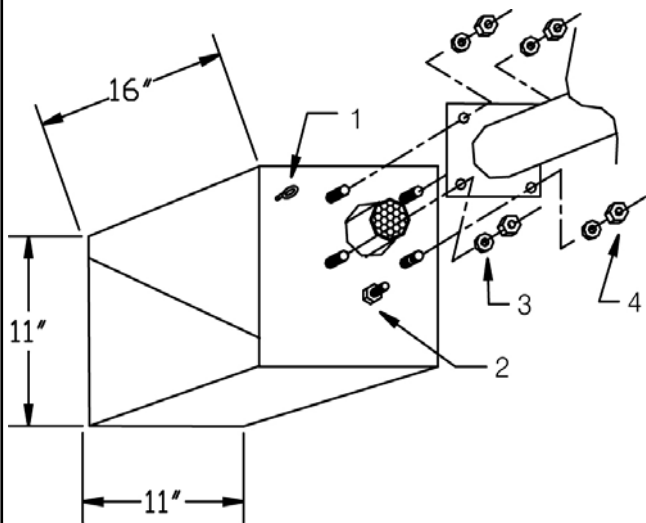

- 1 Eye Bolt
 - 2 Fifth Nut (Holds Inner Burner to Housing - Do Not Remove or Loosen)
 - 3 Lock Washers (4) Four
 - 4 Nuts (4) Four Note: Nuts may be shipped c/w lock-washers as one piece
- Insert four burner bolts through the tube flange, secure tightly with lock washers and nuts.
 - Note: A Flange Gasket is not required for this application
 - Secure suspension chain to eye bolt to stabilize burner
 - Align the four burner bolts through flange on tube, secure tightly with lock washers and

FIGURE 9 COUPLER

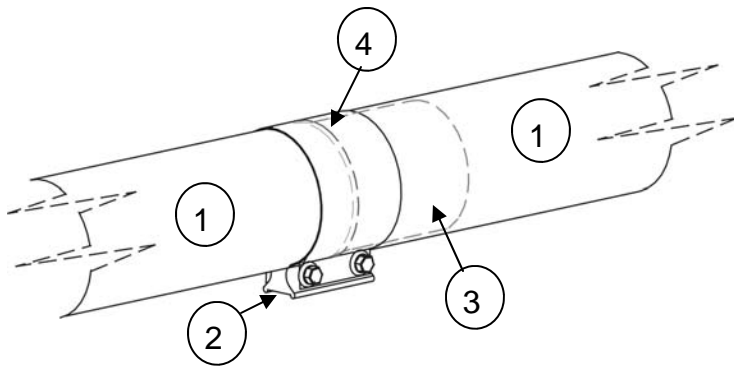

- 1 Tube
 - 2 Tube Coupler
 - 3 Swaged section of upstream tube
 - 4 End of downstream tube
- 5 Place the centre of the coupler over the line of the tube joint (end of downstream tube)
 - 6 Tighten bolts to 40 ft-lbs.

FIGURE 10 HANGER / REFLECTOR ORIENTATION HORIZONTAL TO 45°

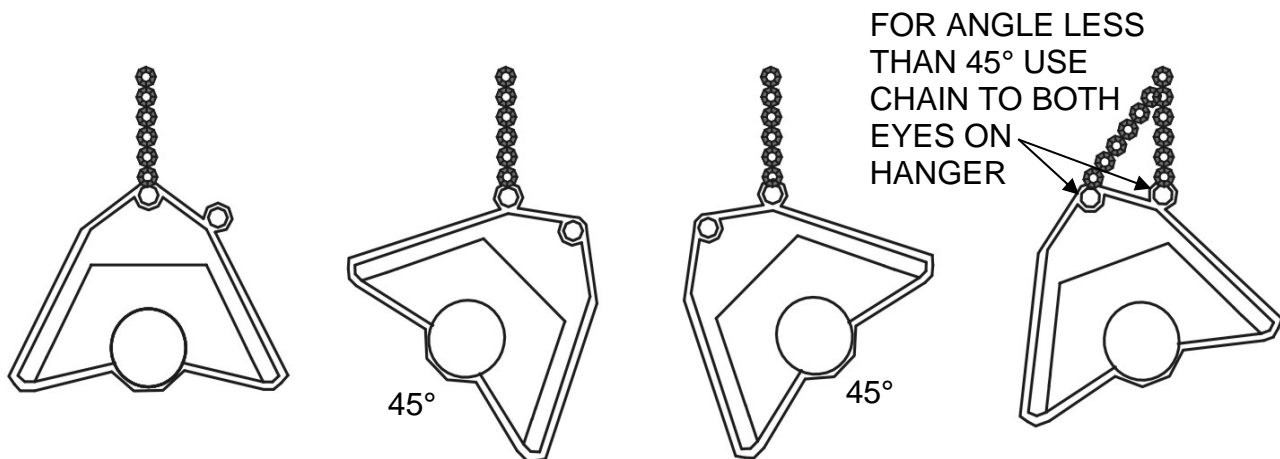

9.2 IRBU 'U'-TUBE SYSTEM ~ BURNER AND TUBE INSTALLATION

Note: Turbulators are ALWAYS installed at the vent end of the heater .

- 1) Install Hangers using chain or other suitable suspension hardware at each side of the hanger: See Figure 11 next page
 - i: Two hangers for first section (from burner), and one hanger for each additional section
 - ii: No closer than 12" (30 cm) and no further than 14" (35 cm) from the burner/tube flange
 - iii: No closer than 6" (15 cm) from a tube connection in the system
 - iv: No further than 18" (61 cm) from a tube connection in the system
 - v: If angle mounting a 'U' Tube model, the vent side must be in the upper position
- 2) With all hangers in alignment and suspended at the same height (and angle), insert first aluminized tube section on to the first two hangers: See Figure 12A next page
 - Also lay the vent end tube on to the first two hangers - check tubes for turbulator label to ensure the correct tube is located at the vent end

NOTE: INSTALL THE FIRST AND SECOND TUBES (FROM BURNER) WITH THE WELDED SEAM ALONG THE TUBE LENGTH FACING DOWNWARD
- 3) Fasten flanged tube to hangers with 'U' bolts:
 - All tubes on the burner-side of the heater are bolted to the hangers with 'U' bolts
 - Tubes on vent-side simply rest in the hanger notch and do not fasten to the hanger.
- 4) Bolt burner to flange on first tube section - SEE FIGURE 8 previous page.
- 5) Slide a Torctite tube coupler over the swaged end of the first tube, then join the second tube over the swage in the first tube -
- 6) Slide the Torctite coupler into position across the center of the tube joint - SEE FIGURE 9
- 7) IMPORTANT: **TOURQUE THE COUPLER BOLTS TO 40 ft-lbs**
- 8) Subsequent lengths of tube can then be installed on both sides of the hangers by joining them together swaged portion inside the next tube and locking the joints using the Torctite coupler. SEE FIGURE 9.
- 9) Install Turn Box: See Fig 12B next page
 - The Turn Box has "long" and "short" tube legs
 - The 'long' leg attaches to the burner-run tubes
 - The 'short' leg attaches to the vent-run tube side - tubes end short of burner for connection of vent pipe

FIGURE 11 'U'-TUBE TYPICAL HANGER & SUPPORT SPACING

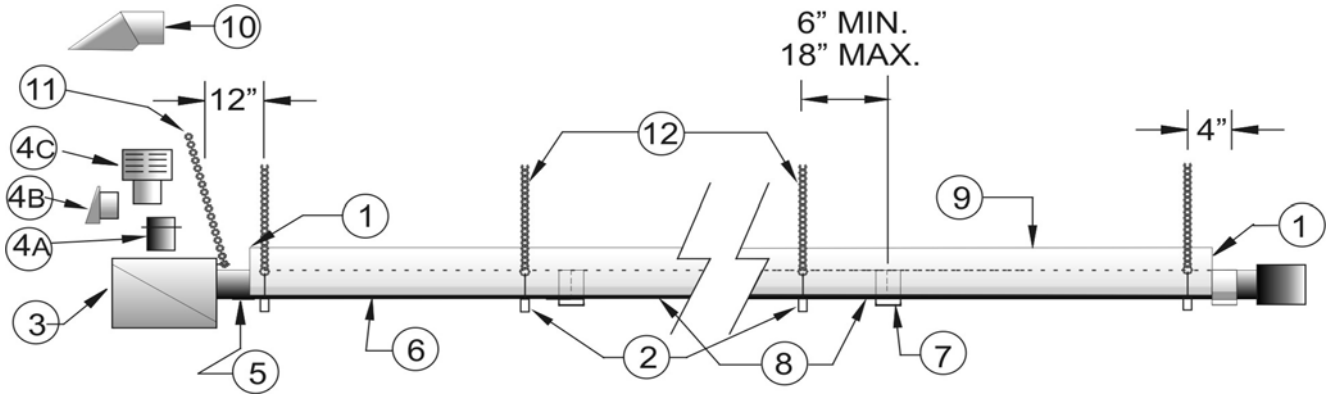

SUSPEND FIRST TUBES BY TWO (2) HANGERS, THEN SUBSEQUENT SECTIONS BY ONE HANGER
 LOCATE HANGERS BETWEEN 6" to 18" FROM EACH TUBE COUPLER.
 INSTALL FIRST AND SECOND TUBES (FROM BURNER END) WITH WELDED SEAM FACING DOWNWARD.

- | | | |
|---|------------------------------------|-------------------------------|
| 1 - END CAP | 4B - JS-0532-VC 4" WALL CAP | 8 - STEEL TUBE(S) |
| 2 - WIRE HANGER | 4C - JA-0528-XX 4" ROOF CAP | 9 - REFLECTOR |
| 3 - BURNER ASSEMBLY | 5 - SIGHT GLASS | 10 - FLUE VENT TERMINAL |
| 4 - COMBUSTION AIR OPTIONS: 4A - JS-0532-SE 4" INTAKE ADAPTER | 6 - ALUMINIZED TUBE WITH FLANGE | 11 - BURNER SUPPORT CHAIN |
| | 7 - TORCTITE TUBE COUPLER | 12 - HANGER SUPPORT CHAINS |

FIGURE 12 'U' TUBE MODELS

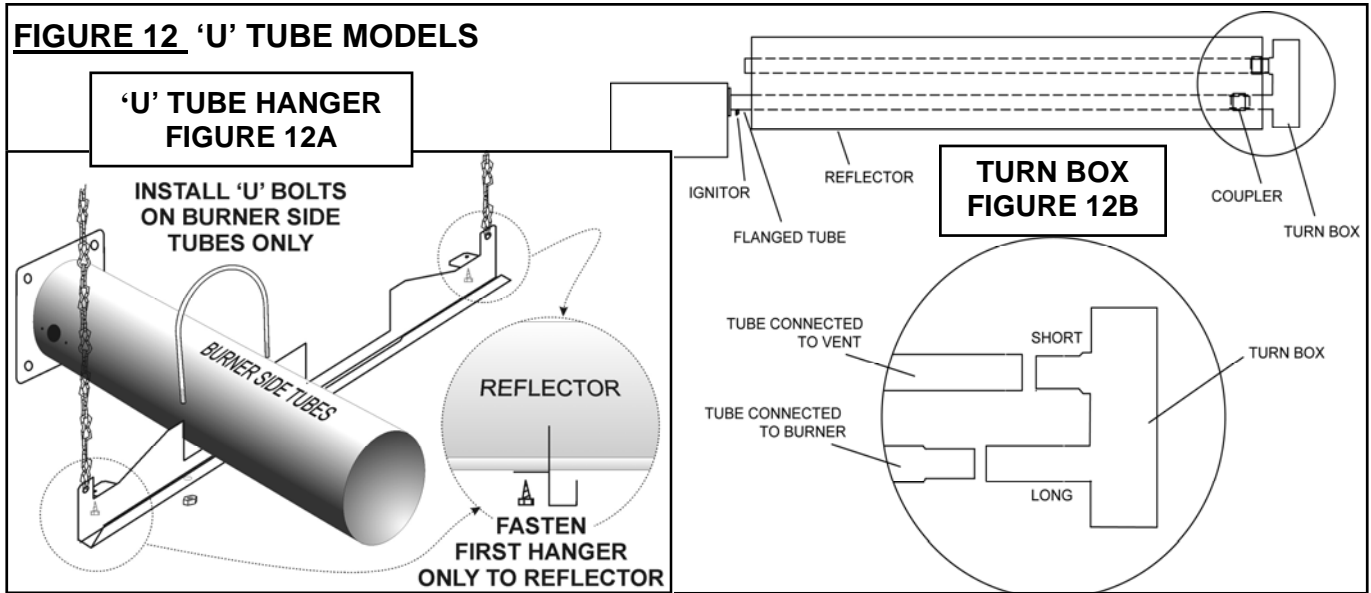
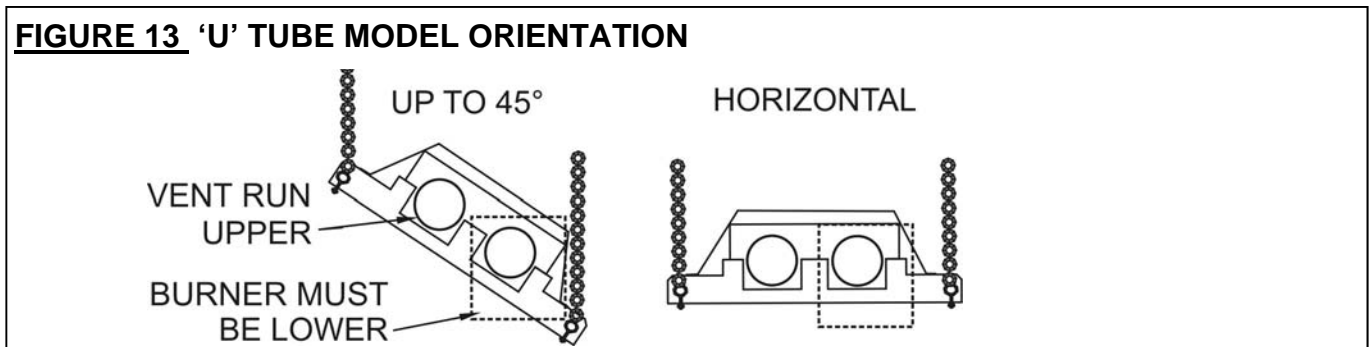

FIGURE 13 'U' TUBE MODEL ORIENTATION



10. REFLECTOR INSTALLATION

NOTE: Ensure that you are installing a single reflector - reflectors can 'stick together' in packaging - take care to separate them.

IRB - STRAIGHT TUBE: After burner and tubes have been installed, slide the reflectors one at a time into the wire hangers. As each successive reflector is installed on an in-line installation, the ends of the reflectors will overlap to provide continuous coverage over the entire tube system. The overlapping joints **MUST BE FASTENED TOGETHER** with a sheet metal screw.

Note that for either horizontal or angle mounting of the reflector, the tube must be level along its length. Improper mounting can result in overheating of controls and combustible materials.

Reflector extensions can be added to the heaters as an option. *See Figure 15 and instructions next page*

IRB-U - U'-TUBE: After burner and tubes have been installed, slide the double-wide reflectors one at a time onto the hangers. Fasten the FIRST hanger nearest the burner to the reflector with a sheet metal screw up through the hole in the tab at each end of the hanger.

Do not fasten any other hangers in the system to reflectors. SEE FIGURE 12A

As each successive reflector is installed, the ends of the reflectors will overlap to provide continuous coverage over the entire tube system. The overlapping joints **MUST BE FASTENED TOGETHER** with sheet metal screws - Note that for both horizontal and angle mounting, the tube must be level along its length. Improper mounting can result in overheating of controls and combustible materials.

Reflector extensions can be added to the heaters as an option. *See Figure 15 and instructions next page*

FIGURE 15 REFLECTOR EXTENSIONS

(OPTIONAL - IF REQUIRED)

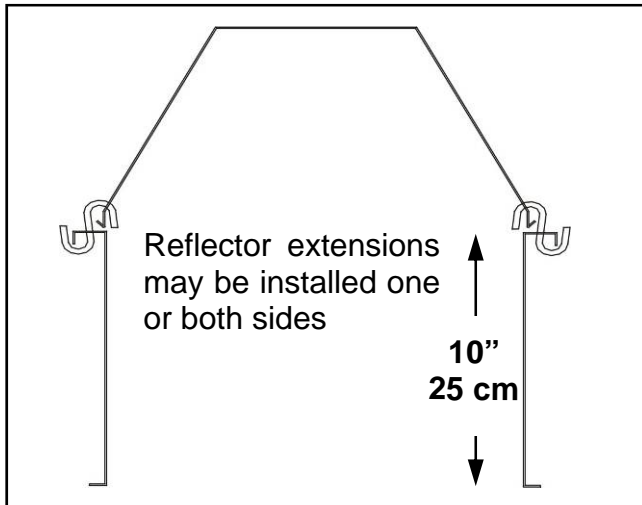

Reflector Extension Kit JS-0509-KT

Includes:

- Qty 1 x 10 ft long x 10 inch deep reflector extension
- Qty 3 x "S" Hooks

1. Reflector extensions may be installed on one side or both sides of the reflector
2. Reflector extensions are 116" (295 cm) long
3. Holes (3) in the reflector extension for "S" hooks are located 2.25" (5.7 cm) from each end and one at the center
4. Drill 1/4" (7 mm) holes in the reflector 3/4" (2 cm) up from the bottom edge of the reflector to align with the 3 holes in the top of the reflector extension
5. Insert "S" hook down through hole in the top of the reflector extension
6. Rotate "S" hook approx. 90°, and insert into hole drilled in reflector
7. Settle reflector extension into place

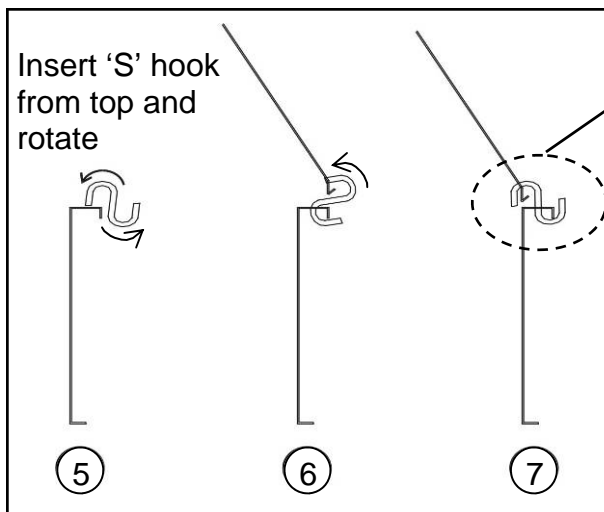
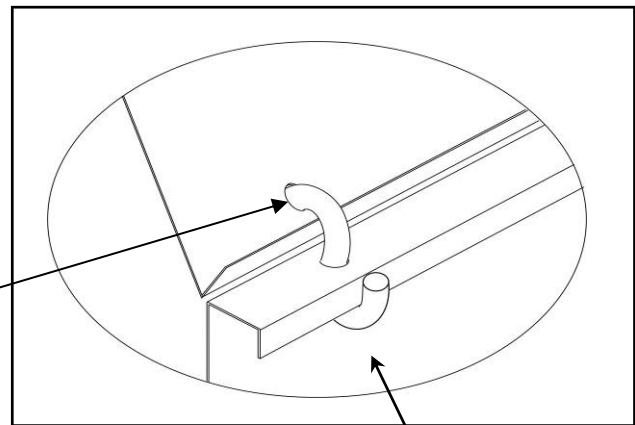



WARNING

11. FLUE VENTING



Inadequate venting of a heater may result in asphyxiation, carbon monoxide poisoning, injury or death. This heater may use a vent connection or indirect venting system to remove products of combustion from the space. Seal all vent connections with high temperature sealant. Venting must be in accordance with all local, state, provincial, and national codes (ANSI Z223.1/NFPA 54 in USA; B149.1 in Canada) and as indicated below in this manual.

THIS TUBE HEATER IS APPROVED FOR VENTING DIRECTLY TO THE OUTSIDE AND UNVENTED (INDIRECT VENTING) APPLICATIONS. THE SYSTEM MUST NOT BE OPERATED WITHIN A NEGATIVE AIR CONDITION UNLESS COMBUSTION AIR IS DUCTED FROM OUTSIDE DIRECTLY TO THE BURNER.

IF NEGATIVE PRESSURE IS EXPERIENCED OR ANTICIPATED, THE SECOND PORT (BARB) ON THE BLOCKED FLUE SWITCH SHOULD BE CONNECTED DIRECTLY TO OUTSIDE AIR USING 1/4" PLASTIC HOSE FROM BLOCKED FLUE SWITCH TO OUTSIDE OF BUILDING (FIELD SUPPLIED).

UNVENTED (INDIRECT MECHANICAL VENTING SYSTEM)

Indirect venting must not be used if the building experiences a negative air condition. A minimum 10 inch (25 cm) length of single walled vent pipe is to be installed on the swaged end of the last tube before any Tee, Elbow or Termination Cap is fitted.

USA: Natural or mechanical means shall be provided to supply and exhaust at least 4ft³/min/1000Btuh (0.38m³/min/kW) input of installed heaters. Some local codes may require an electrical interlock to a dedicated exhaust fan. Exhaust must be located as high as practicable in the structure above the level of the heater(s). Consult your local code and ANSI Z223.1 latest edition for all venting requirements and practices.

Canada: It is required that the heater(s) be electrically interlocked to dedicated exhaust fan(s) by means of an Air Proving Switch. Exhaust fan(s) must be sized to create 300 cfm (8.5 cu m/min) exhaust for every 100,000 Btuh (30 kW) or any fraction thereof of total input of installed equipment. Exhaust must be located as high as practicable in the structure above the level of the heater(s). Sufficient supply air must be provided. Consult the latest edition of CSA.B149.1 Section 8 for venting system and air supply requirements.

VENTED DIRECTLY TO THE OUTSIDE

It is the sole responsibility of the installer to adhere to all current local codes and/or ANSI Z223.1 / CSA.B149.1 latest editions for all venting requirements, and practices.

It is a normal condition that during heat-up and cool-down a tube heater will expand and contract. Allowances for heater expansion must be made in the venting and combustion air ducting. Improper installation can result in property damage, injury or death.

- All vent pipe and adapters are supplied locally by others
- All venting must be minimum 26 gauge single wall vent pipe of 4" (10 cm) diameter except that portion of vent passing through a combustible wall or roof can be 4" type "B" vent as per CSA International's interim requirement. Refer to Section 11A for vent length requirements.
- As an Option, two heaters may be vented through an approved common 4" x 4" x 6" Vent Tee (10 x 10 x 15 cm), supplied by the manufacturer. Vent pipe from each heater does not need to be equidistant to the vent Tee, but must comply to requirements below. The two

heaters must be controlled by a single common thermostat or “ON/OFF” switch.

- A minimum 10 inch (25 cm) length of minimum 26 gauge single walled 4” (10 cm) diameter vent pipe is to be installed on the swaged end of the last tube before any Tee or Elbow is fitted.
- Seal all vent connections with high temperature sealant. Vent connections must be secured with three (3) #8 sheet metal screws uniformly spaced around the circumference of the vent pipe.
- When the vent pipe passes through a cold or unheated area where the ambient temperature is likely to produce condensation of the flue gases, the vent pipe shall be insulated with a suitable material as approved and specified by the insulation manufacturer to withstand temperature up to 460°F (238°C).
- The vent system must **always** be adequately supported to prevent sagging.

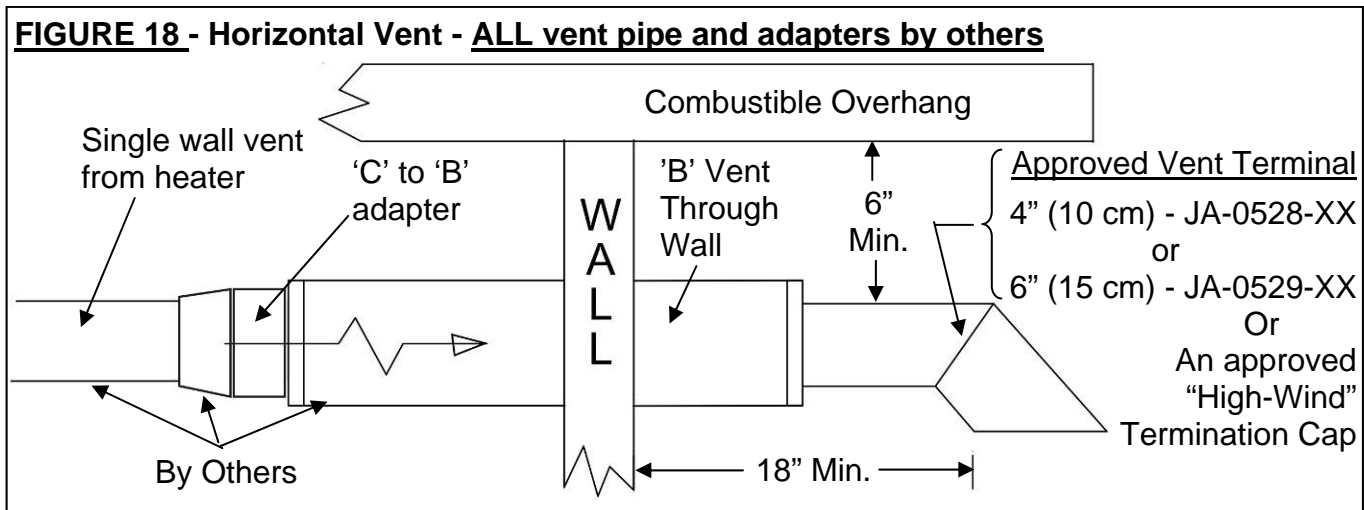
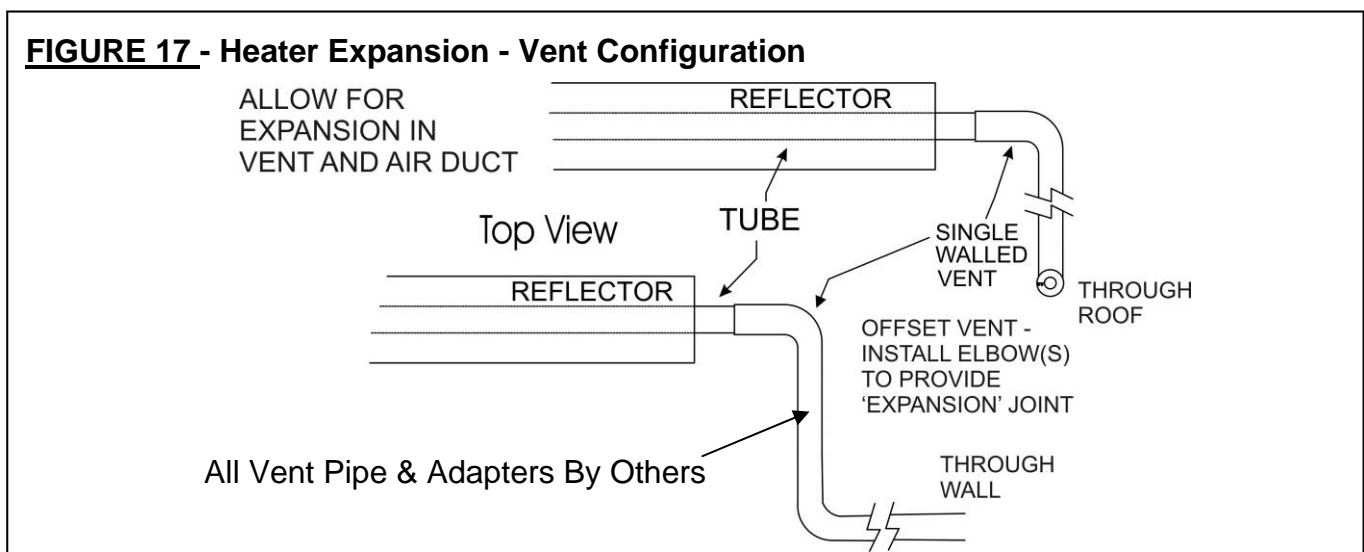

HORIZONTAL VENT THROUGH THE SIDEWALL:

- The flue vent system must slope downwards approximately 1/4" per ft (63 mm/ 300 mm) toward the vent terminal, starting at the termination of the radiant tube - radiant tube must be level.

- Use the approved 4" (10 cm) (JA-0528-XX) or 6" (15 cm) (JA-0529-XX) horizontal wall vent terminal or a high-wind termination cap approved by a recognized certification agency
- Install termination cap a minimum of 18 inches (45 cm) from the outside wall to the inside edge of terminal opening to alleviate back pressure caused by turbulent wind conditions (See Fig. 17). This also ensures flue gases are directed away from the structure to protect building materials from degradation by the exhausted flue gases.
- Must be installed to prevent blockage by snow and protect building materials from degradation by flue gases.

A horizontal flue vent :

- Will not terminate less than 1 ft (30 cm) above grade level, unless its location is adjacent to public walkways, then it must not terminate less than 7 ft (2.1m) above the walkway.
- Will terminate 3 ft (90 cm) or more below or extend beyond a combustible soffit or overhang.

• USA specific horizontal vent requirements:

- The vent terminal of a direct-vent appliance with an input between 10,000 Btu/hr (3 kW) and 50,000 Btu/hr (14.7kW) shall be installed with a 9 inch (230mm) vent termination clearance from any air opening into a building, and an appliance with an input over 50,000 Btu/hr (14.7kW) shall have at least a 12inch (300mm) vent termination clearance. The bottom of the vent terminal and the air intake shall be located at least 12inches (300mm) above grade.
- A horizontal vent will not terminate:
 - Less than 3 ft (90 cm) above a mechanical air inlet located within 10 ft (3.1 m)
 - Less than 4 ft (1.2 m) below, 4 ft (1.2 m) horizontally from, and 1 ft (0.3 m) above any window or door that opens, or gravity air inlet to a building
 - Less than 4 ft (1.2 m) horizontal clearance from gas and electric meters, regulators and relief equipment

• CANADA specific horizontal vent requirements:

- A horizontal vent will not terminate:
 - Within 6 ft (1.8 m) of a mechanical air supply inlet to any building.
 - Above a gas utility meter and regulator assembly within 3 ft (0.9 m) horizontally of the vertical centerline of the regulator vent outlet to a maximum vertical distance of 15 ft (4.5 m).
 - Within 3 ft (90 cm) of any gas pressure regulator vent outlet
 - Within the following distances of a window or door that can be opened in any building, of any non-mechanical air-supply inlet to any building, or of the combustion air inlet of any other appliance:
 - 12 inches (30 cm) for inputs up to and including 100,000 Btuh (30 kW)
 - 3 ft (90 cm) for inputs exceeding 100,000 Btuh (30 kW)

VERTICAL VENT THROUGH THE ROOF:

It is the sole responsibility of the installer to adhere to all current local codes and/or ANSI Z223.1 / CSA.B149.1 latest editions for all venting requirements, and practices.

- Use an approved 'B-vent' termination cap as supplied by the manufacturer of the approved 'B-vent'.
- When vent and combustion air are taken through the roof, the exhaust vent should always terminate higher than the combustion air intake, to prevent recycling the products of combustion back into the heater.

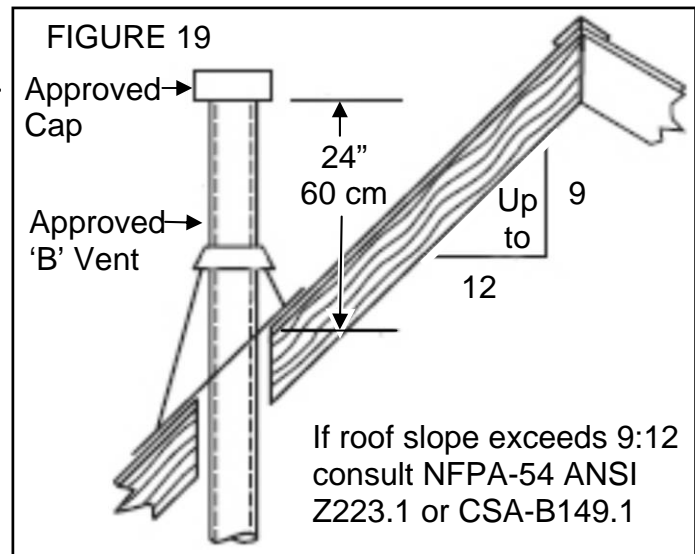

Combined Length of Vent and Combustion Air Duct:

- The individual flue vent or the combustion air duct is not to exceed 50 ft in length.
- Inputs: 45 and 60 Mbh: 50 feet maximum combined vent & duct
- Total combined vent and duct is reduced by ten feet for every 90° elbow installed in the vent or duct, *and* in the tube system
- Exceeding the allowable lengths noted above may create condensation problems and will void CSA Design Certification and the heater warranty.

12. COMBUSTION AIR DUCTING

An opening is located on the top surface of the burner housing for combustion air. Ensure adequate clearance around this opening to allow sufficient combustion air supply to the heater.

When a tube heater is operated in a negative air condition or air-borne dust or contaminants are present as in woodworking and welding shops, air for combustion must be ducted from outside the negative or contaminated area to the 4 inch (10 cm) diameter intake flange supplied on the blower. Maximum vent and duct length is:

- The individual flue vent or the combustion air duct is not to exceed 50 ft in length.
- Inputs: 45 and 60 Mbh: 50 feet maximum combined vent & duct
- Total combined vent and duct is reduced by ten feet for every 90° elbow installed in the vent or duct *and* in the tube system.
- Exceeding the allowable lengths noted above may create condensation problems and will void CSA Design Certification and product warranty.

continued ...

The air intake will not be located less than:

- Three feet above grade
- Twelve inches from flue vent terminal of any heater with input up to 100,000 Btu/hr.

Do not install filters on the combustion air intake.

Ensure adequate clearance around the air intake to allow sufficient combustion air supply to the heater.

This heater has an optional fresh air intake duct hood for wall (JS-0532-VC) or roof cap (JS-0530-XX) to bring combustion air to the heater from outside. Ensure adequate clearance around the air intake to allow sufficient combustion air supply to the heater. If drawing fresh air from outside, it is recommended that any single wall pipe containing cold air be insulated to prevent or reduce condensation on the pipe.



Do not use flexible dryer hose or any 'soft wall' tubing for air inlet duct, the corrugated sides of this tubing restrict air flow. A good quality industry approved insulated flex is allowed.



CAUTION: In locations where chlorinated Hydrocarbons are in use, such as Trichloroethylene or Chloroethylene Nu it is essential that combustion air be brought in from a non-contaminated area. Burning the fumes from these gases will create Hydrochloric acid fumes, which are detrimental to humans, equipment and buildings. Typical sources of other contaminants are paint removers, paints, refrigerants, solvents, adhesives, degreasers, lubricants, pesticides, etc.

The heater manufacturer cannot anticipate all types and chemical composition of possible contaminants at project sites. Confer with project site safety, health and engineering staff and/or local authorities having jurisdiction such as the Fire Marshall and Department of Labor for possible contaminants and any conflict with the installation of hot surface heating equipment.

13. GAS SUPPLY - HEATER EXPANSION - FLEXIBLE GAS CONNECTION

The gas supply must be installed to the heater using:

- **USA:** an approved Stainless Steel Flexible Gas Connector certified for use on an infrared radiant tube heater (ANSI Z21.24 CSA 6.10);
- **CANADA:** an approved Type 1 Hose Gas Connector (CAN/CGA 8.1).
- The heater must be isolated from the gas supply piping system by closing its individual manual shut off valve (field supplied) during any pressure testing of the gas supply piping system.

CAUTION: Compensation for normal gas supply pipe expansion, and radiant tube heater expansion must be provided. All piping must conform to local codes.



Provide a 1/8 in (3.2 mm) NPT plugged tapping, accessible for test gauge connection, immediately upstream of the gas supply connection to the heater.

DO NOT use pressure greater than 1/2 psig to pressure check the heater.



TEST FOR LEAKS: All gas piping and connections must be tested for leaks after the installation is completed.

Apply soap suds solution to all connections and joints and if bubbles appear, leaks have been detected and must be corrected. **DO NOT USE A MATCH OR OPEN FLAME OF ANY KIND TO TEST FOR LEAKS. NEVER OPERATE THE HEATER WITH LEAKING CONNECTIONS.**



The supply system should be checked first with heater turned “OFF” followed by another check with heater turned “ON”.



IMPORTANT: Minimum supply line pressure at the inlet to the heater regulator must not be lower than 5.0 inches of water column pressure for natural gas. The supply gas pressure must be checked with all heaters in operation.



Installation of a gas line (trap) “drip leg” is required at the inlet connection tee following the pipe drop to the heater. Failure to provide a “drip leg” could result in condensation and foreign matter passing into the gas valve. Failure to install a “drip leg” in the gas line can cause property damage, injury or death and will void the heater warranty.

TABLE 4

| GAS TYPE | <u>LINE PRESSURE</u> INCHES WATER COLUMN | | <u>MANIFOLD PRESSURE</u> (tap at gas valve outlet) INCHES WATER COLUMN |
|-------------|---|---------|--|
| | MINIMUM | MAXIMUM | |
| Natural Gas | 5.0 | 14.0 | 3.5 |

NOTE: Access to the manifold pressure test port is on the top of the valve. A 3/16" Allen Wrench is necessary to check this. When checking or setting the manifold pressure, a **water manometer** should be used. Gauges which measure in ounces per square inch or pounds per square inch are not accurate enough to properly measure or set the pressure.

 **WARNING**



THIS HEATER WILL EXPAND IN LENGTH AS IT HEATS UP. It is a normal condition that during heat-up and cool-down a tube heater will expand and contract. Allowances for heater expansion must be made in the gas connection, venting and combustion air ducting. Improper installation, alteration, or adjustment can result in property damage, injury or death.



The Btuh input and the tube length determine the overall expansion that occurs. A typical infrared tube installation will expand toward both the Burner and the vent end.



To allow heater expansion the gas supply must be installed using the flexible gas connector supplied in the burner kit:

In the USA: a stainless steel Flexible Gas Connector certified for use on an infrared radiant tube heater (ANSI Z21.24 CSA 6.10);

in CANADA: a Type 1 Hose Connector (CAN/CGA 8.1). Also the flue vent, and combustion air intake (if used) must be installed in such a manner that the normal expansion of the heater will be accommodated.

 **IMPORTANT:** See next page: orientation of connection between heater and gas supply.

TABLE 5

| Input Rating Btuh | Tube Length Feet | Approx. Expansion in Length | USA: Mandatory Flexible Gas Connector ID x Length - Part # | CANADA: Mandatory Type '1' Gas Hose Size - Part # |
|-------------------|------------------|-----------------------------|--|---|
| 45,000 | 10 | 1" | 1/2" x 24" - JL-0771-XX | 1/2" x 36" - JL-0771-RC |
| 45,000 | 20 | 1 1/4" | 1/2" x 24" - JL-0771-XX | 1/2" x 36" - JL-0771-RC |
| 60,000 | 20 / 30 | 1 1/2" | 1/2" x 24" - JL-0771-XX | 1/2" x 36" - JL-0771-RC |

FIGURE 20 ORIENTATION OF FLEXIBLE GAS CONNECTOR



The flexible gas connector **MUST** be installed in the orientation shown below as required by national installation codes and by the certification standard of this heater. This orientation protects the flexible gas connector from damage due to movement during heater expansion.

It is the responsibility of the installer to ensure correct installation of the flexible gas supply.

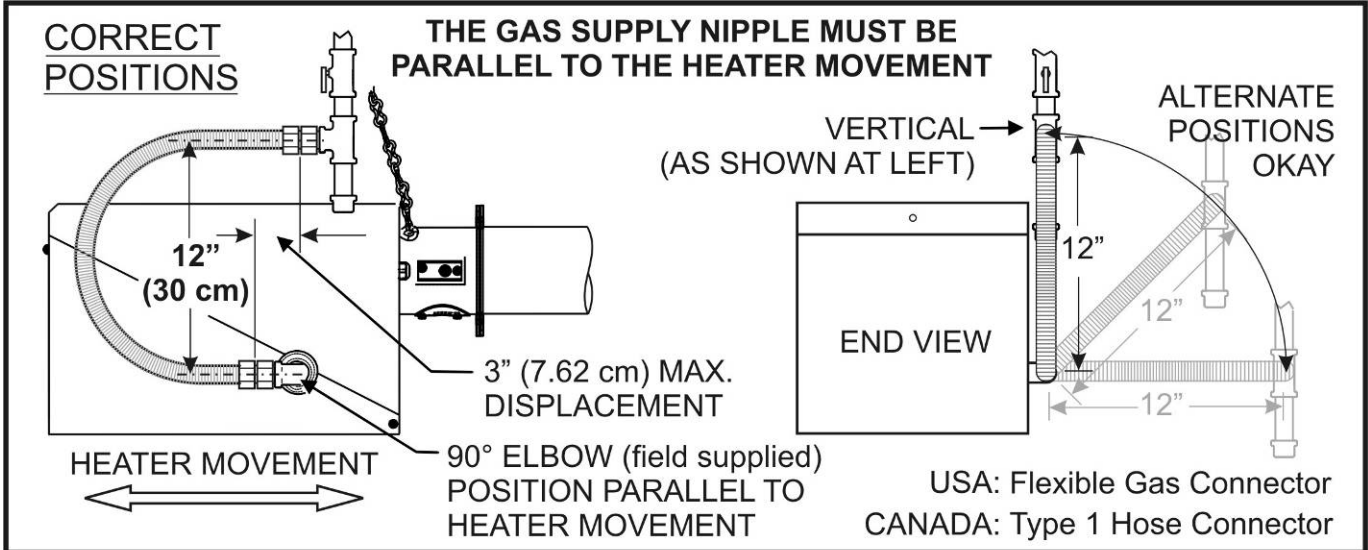

WARNING: CONNECTOR MUST BE INSTALLED IN "C" CONFIGURATION. USE ONLY THE CONNECTOR OF PROPER LENGTH AND NOMINAL ID THAT IS FURNISHED WITH THIS HEATER - SEE TABLE PREVIOUS PAGE.

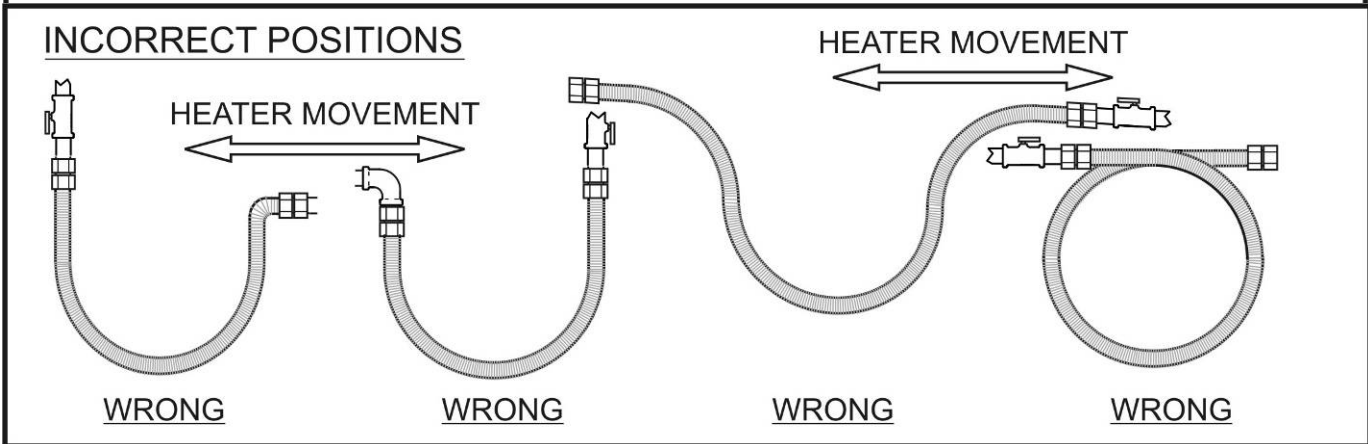

The flue vent, and combustion air duct (if installed) must also be configured in such a manner that the normal expansion of the heater will be accommodated. **See Section 11.**

14. ELECTRICAL AND THERMOSTAT WIRING (WIRING DIAGRAMS PAGE 35 & 36)



NOTICE

The heater must be electrically grounded in accordance with the National Electrical Code. ANSI / NFPA 70 or current Canadian Electrical code CSA C22.1.

Appliance and control wiring must be in accordance with all applicable local codes. The total load of all heaters must be considered in determining the required contact rating of the controlling thermostat or switch. Each tube heater requires 120V, 60 HZ electrical power sized for 145VA. The heater includes a 24V/120V relay switch and can be controlled by a 24V Thermostat, a TruTemp Thermostat, a line voltage Thermostat or by an "ON/OFF" switch. Maximum power flow for internal 24V burner components is 21VA.

A maximum night set-back of 9°F (5°C) is recommended for optimum economy and comfort. To maintain satisfactory comfort levels do not turn off the heating system over night/weekends.

15. HIGH ALTITUDE INSTALLATIONS - *also refer to chart in Section 28*

When this appliance is installed above the altitude stipulated below for the USA or Canada, the input must be de-rated by 4% for each 1000 ft above the altitude listed . **If your local utility supplies gas with a de-rated heat content, no orifice change is required in the heater** . If the gas supply is not de-rated, the orifice must be changed according to the chart in Section 28. Check with your local utility regarding the gas supply and the de-rating of this appliance.

USA: The factory installed orifice for this appliance is approved for altitudes zero to 2000 feet above sea level. When installed above 2000 feet, **refer to Section 28**.

Canada: The factory installed orifice for this appliance is approved for altitudes zero to 4500 feet above sea level. When installed above 4500 feet, **refer to Section 28**.

16. LIGHTING INSTRUCTIONS

Refer to the lighting instructions label on the outside of the burner housing. If the unit locks out on safety, main power to the unit must be manually interrupted for a 30 second reset period before the heater can be restarted.

NOTE: *On initial installation, the unit may lock out on safety owing to the length of time required to bleed air from the gas piping system.*

17. RECOMMENDED MAINTENANCE



Improper adjustment, alteration, service or maintenance can cause property damage, injury or death. This heater must be installed and serviced only by a trained gas service technician.

1. Inspect the entire heater system, venting, and gas supply connections at least annually prior to the heating season. Replace worn parts and repair deficiencies.
2. Check the inlet air opening and the blower periodically, cleaning off any lint or foreign matter. It is important that the flow of combustion and ventilation air must not be obstructed.
3. Lubricate Blower motor, by adding several drops of oil to oil ports located on the left hand side of the motor.

THE TUBE HEATER BURNER IS COMPLETELY FACTORY ASSEMBLED AND TESTED. ANY ALTERATION VOIDS THE CSA CERTIFICATION AND MANUFACTURER'S WARRANTY. FOR ADDITIONAL INFORMATION, CONTACT YOUR LOCAL DISTRIBUTOR OR MANUFACTURER.

18A. WIRING DIAGRAM: 120 VOLT THERMOSTAT OPERATION

(24V Thermostat—next page)

SPARK IGNITION - LINE VOLTAGE THERMOSTAT / SWITCH

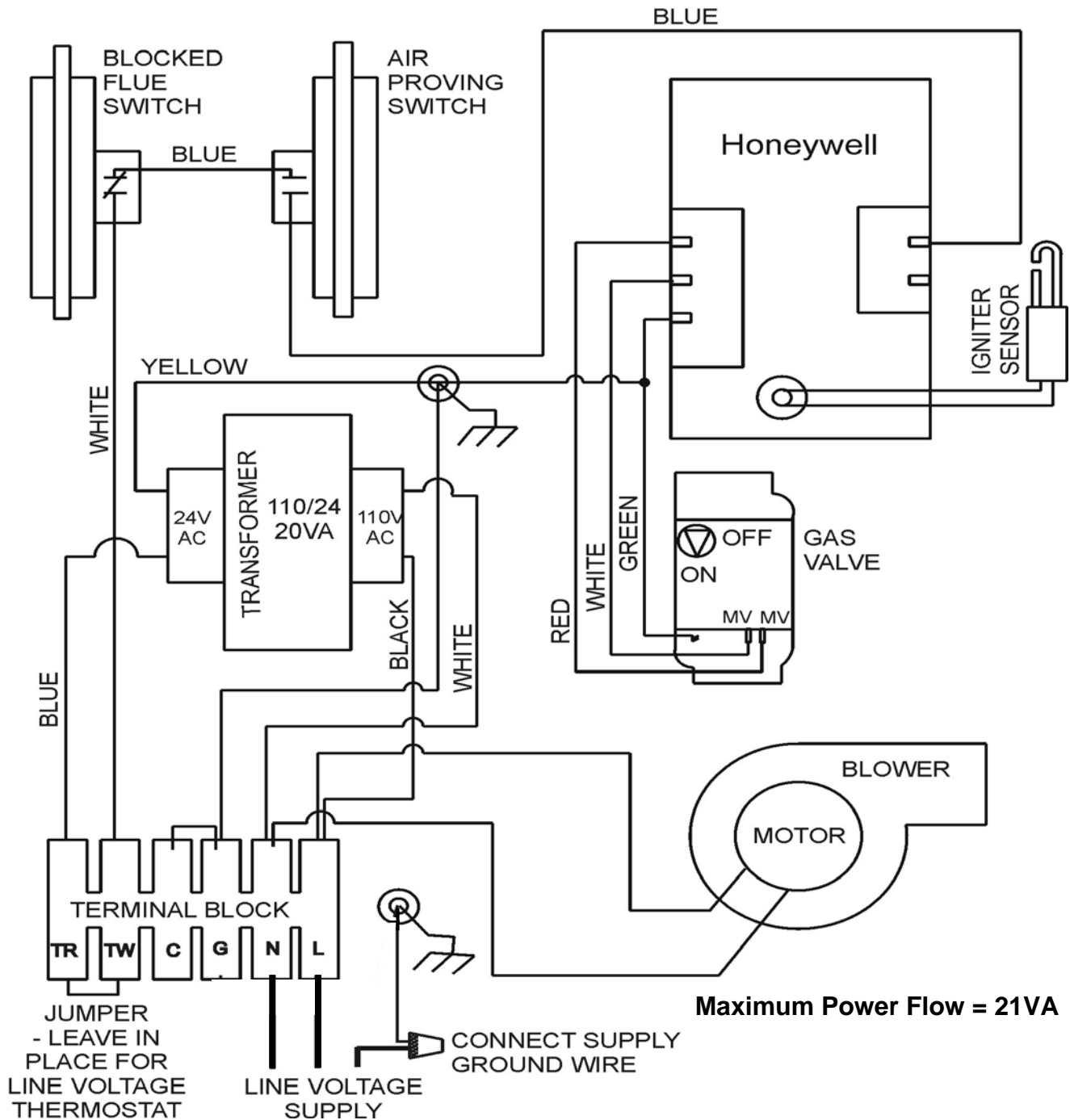

Maximum Power Flow = 21VA

Each tube heater requires 120V, 60 HZ electrical power sized for 145VA. The heater includes a 24V/120V relay switch . Maximum power flow for internal 24V burner components is 21VA.

The heater must be electrically grounded in accordance with the National Electrical Code. ANSI / NFPA 70 or current Canadian Electrical code CSA C22.1.

A maximum night set-back of 9°F (5°C) is recommended for optimum economy and comfort. To maintain satisfactory comfort levels do not turn off the heating system over night/weekends.

18B. WIRING DIAGRAM: 24 VOLT THERMOSTAT OPERATION

(120V Thermostat - previous page)

DIRECT SPARK IGNITION - 24V THERMOSTAT / SWITCH

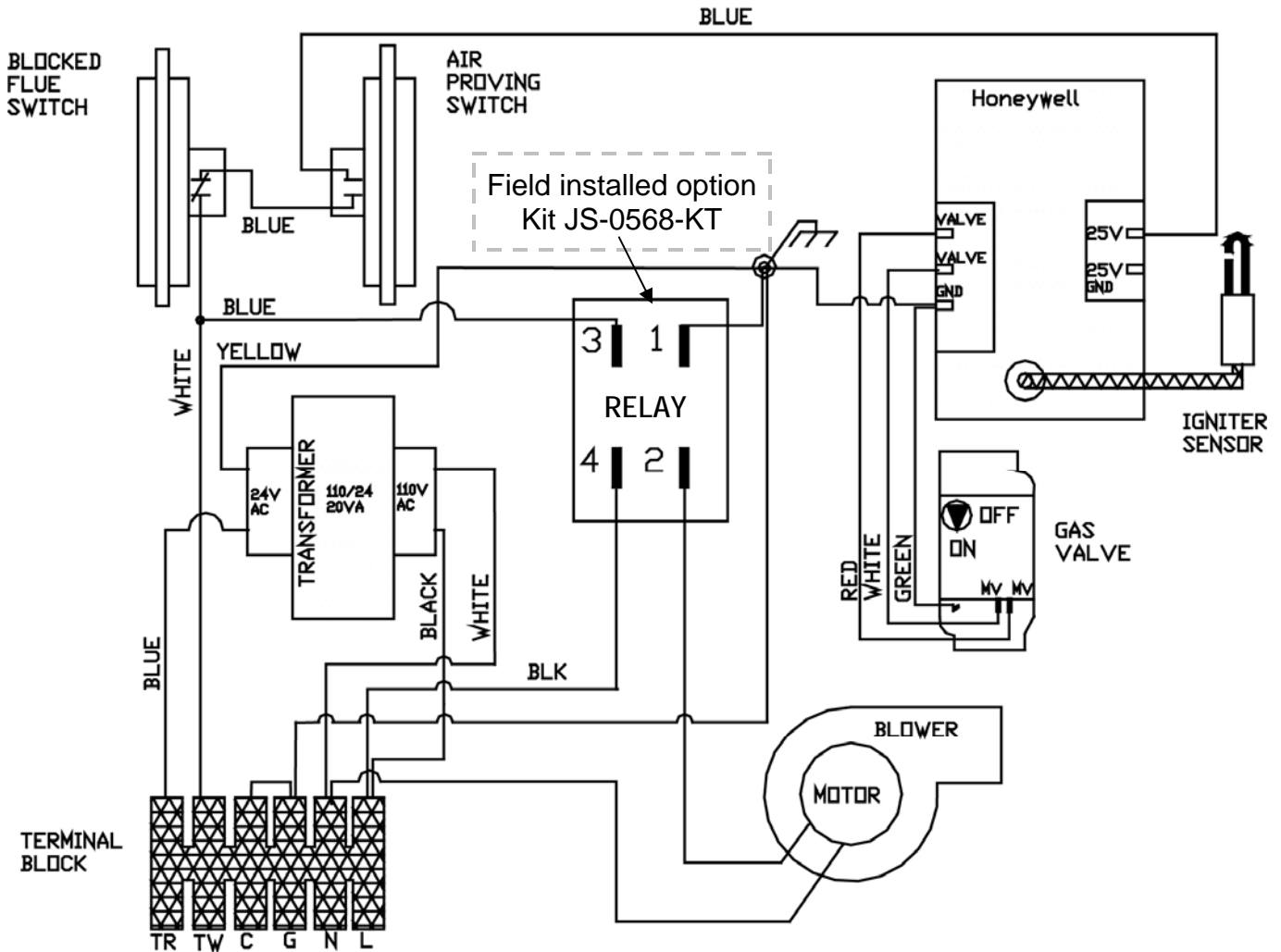

SP-WSTP-AX-01B

Maximum Power Flow = 21VA

Each tube heater requires 120V, 60 HZ electrical power sized for 145VA. The heater includes a 24V/120V relay switch . Maximum power flow for internal 24V burner components is 21VA.

The heater must be electrically grounded in accordance with the National Electrical Code. ANSI / NFPA 70 or current Canadian Electrical code CSA C22.1.

A maximum night set-back of 9°F (5°C) is recommended for optimum economy and comfort. To maintain satisfactory comfort levels do not turn off the heating system over night/weekends.

19. MULTIPLE TUBE HEATERS per THERMOSTAT

24V Thermostat Connection

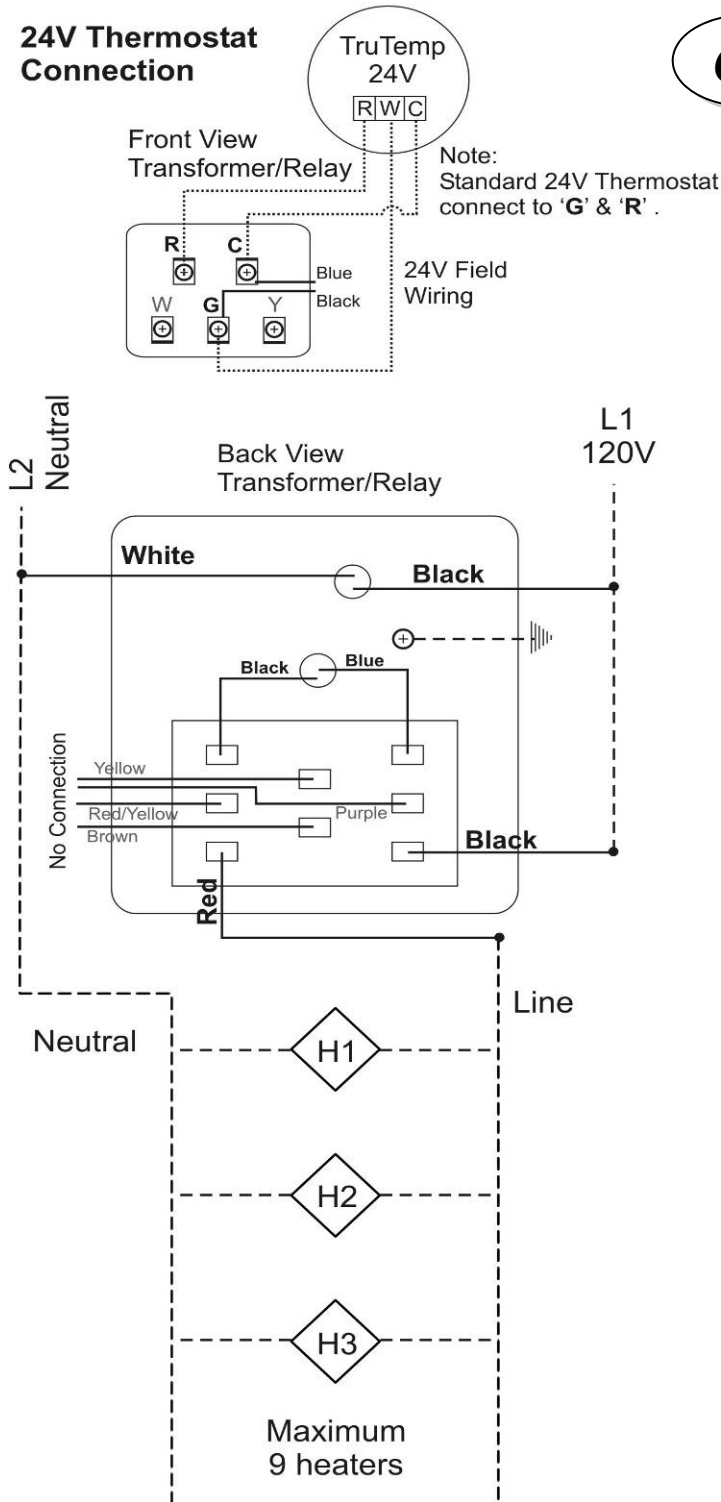

OR

Line Voltage Thermostat

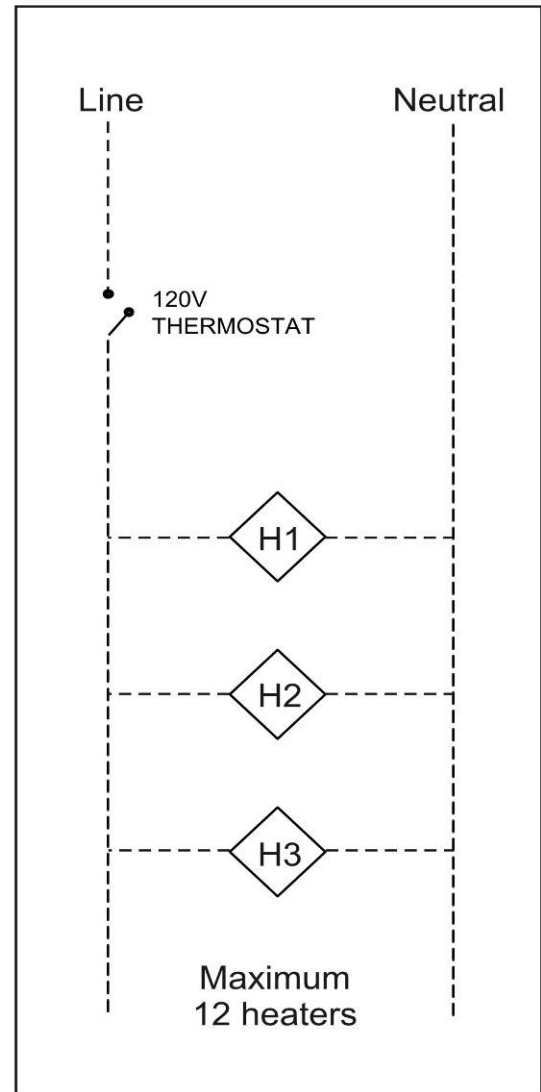

----- Line Voltage Field Wiring
 Low Voltage Field Wiring

Each tube heater requires 120V, 60 HZ electrical power sized for 145VA. Maximum power flow for internal 24V burner components is 21VA. **See previous pages for internal wiring.**

The heater must be electrically grounded in accordance with the National Electrical Code, ANSI / NFPA 70 or current Canadian Electrical code CSA C22.1.

A maximum night set-back of 9°F (5°C) is recommended for optimum economy and comfort. To maintain satisfactory comfort levels do not turn off the heating system over night/weekends.

20 SEQUENCE OF OPERATION

The S87 ignition control module is powered by a 24v transformer and activated when the thermostat calls for heat. On every call for heat the S87J will delay start-up to provide a 30 second system pre-purge. When the S87 is activated by a thermostat or call for heat an internal transformer provides power to the electronic generator circuit for Spark Ignition and the safety lock-out timing begins. At the same time, the S87 opens the gas controls main valve allowing gas to flow to the main Burner.

The S87 Control Module performs the following basic functions:

- Provides a 30 second system pre-purge
- Supplies power to the electronic pulse-generator circuit for the Spark Igniter (30,000 volts open circuit).
- Allows 21 seconds for Ignition trial (TFI) before system safety lockout occurs.
- Senses the Burner flame for safe lighting
- Shuts off the spark after the Burner is lit.

Burner with direct spark ignition, sequence is as follows :

1a. **Line Voltage Thermostat:** Upon a call for heat by the line voltage Thermostat or “ON/OFF” switch, the Blower and the 120/24 Volt Transformer in the burner are powered simultaneously with 115 volts.

1b. **TruTemp / 24 Volt Thermostat:**

Requires: Single heater per 24V thermostat - Relay Kit JS-0568-KT - installs in burner

Multiple heaters per 24V Thermostat - Control Center JM-0303-KT

The 120 volt supply to heater will power the 120v/24v Transformer and the 120V side of the Blower switching relay simultaneously. A call for heat by the 24 volt Thermostat energizes the 24 volt control circuit and the 24v/120 volt relay powering the Blower.

2. The 24 volt control circuit powers the DSI control in series through the normally open Air Pressure Switch (APS) and the normally closed Blocked Flue Switch (BFS).
3. The Blower creates a positive pressure and closes a normally open contact inside the Air Proving Switch (APS).
4. 24 volts supplied to the DSI control initiates the 30 second pre-purge cycle.
5. After completing the 30 second pre-purge cycle the DSI control generates high voltage to the Spark Igniter, and 24 volts to energize the Gas Valve.
6. The Burner will light and establish a steady flame.
7. Once the flame sensor determines there is a steady flame established, with a minimum flame signal of 1.5 μ A the spark igniter is then de-energized.
8. In the event ignition does not occur, the safety circuit will function to interrupt gas flow after approximately 21 seconds and lock the system out. No further gas will flow until the power has been manually interrupted for a period of 30 seconds. This will reset the ignition module and the operating sequence will restart at step #1
9. If the blower does not run, the blower air pressure switch (normally open contact) does not close and power is not supplied to the ignition control.

21. TROUBLESHOOTING GUIDE



WARNING

Improper adjustment, alteration, service or maintenance can cause property damage, injury or death. This heater must be installed and serviced only by a trained gas service technician

SEQUENCE OF EVENTS

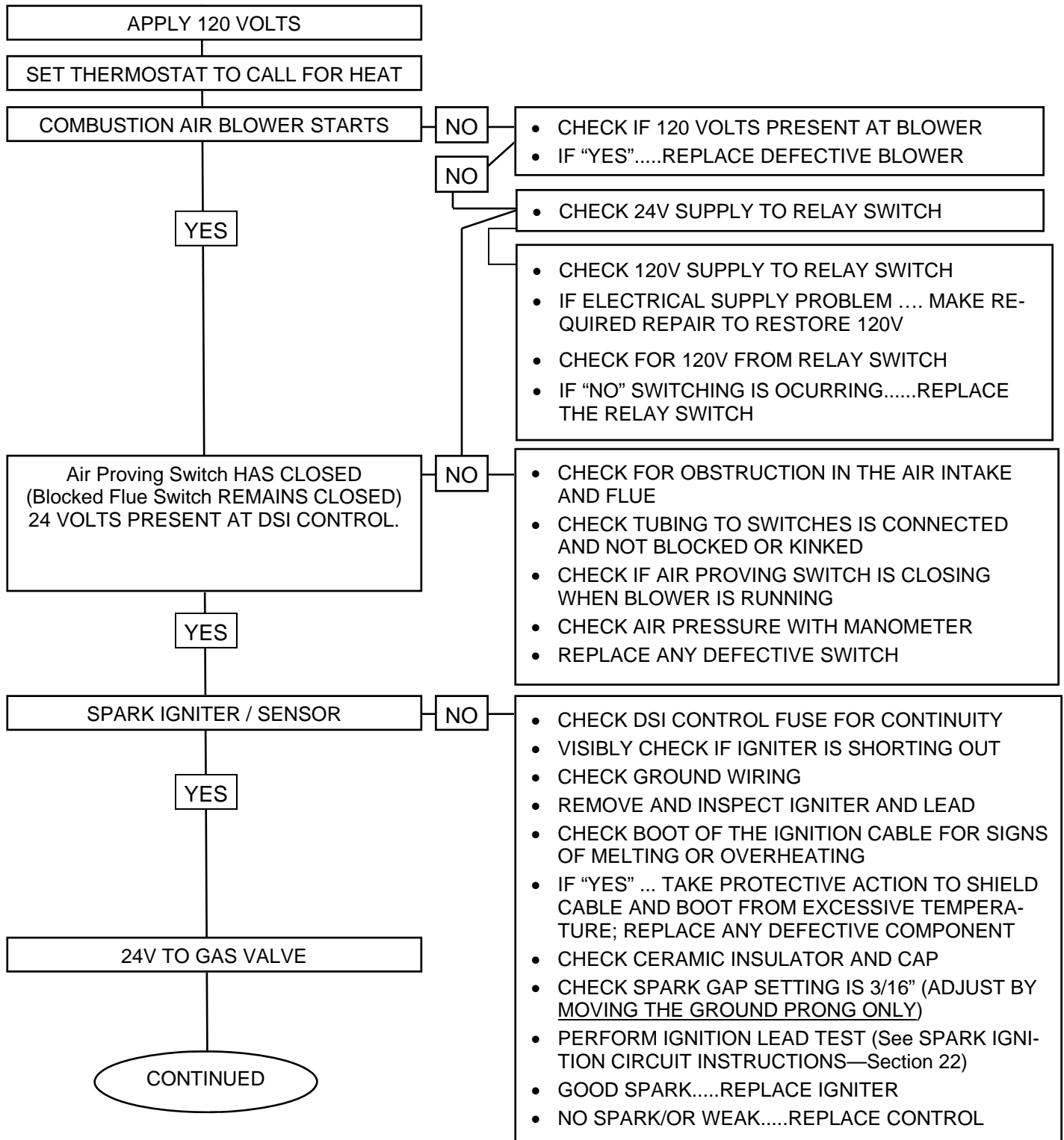

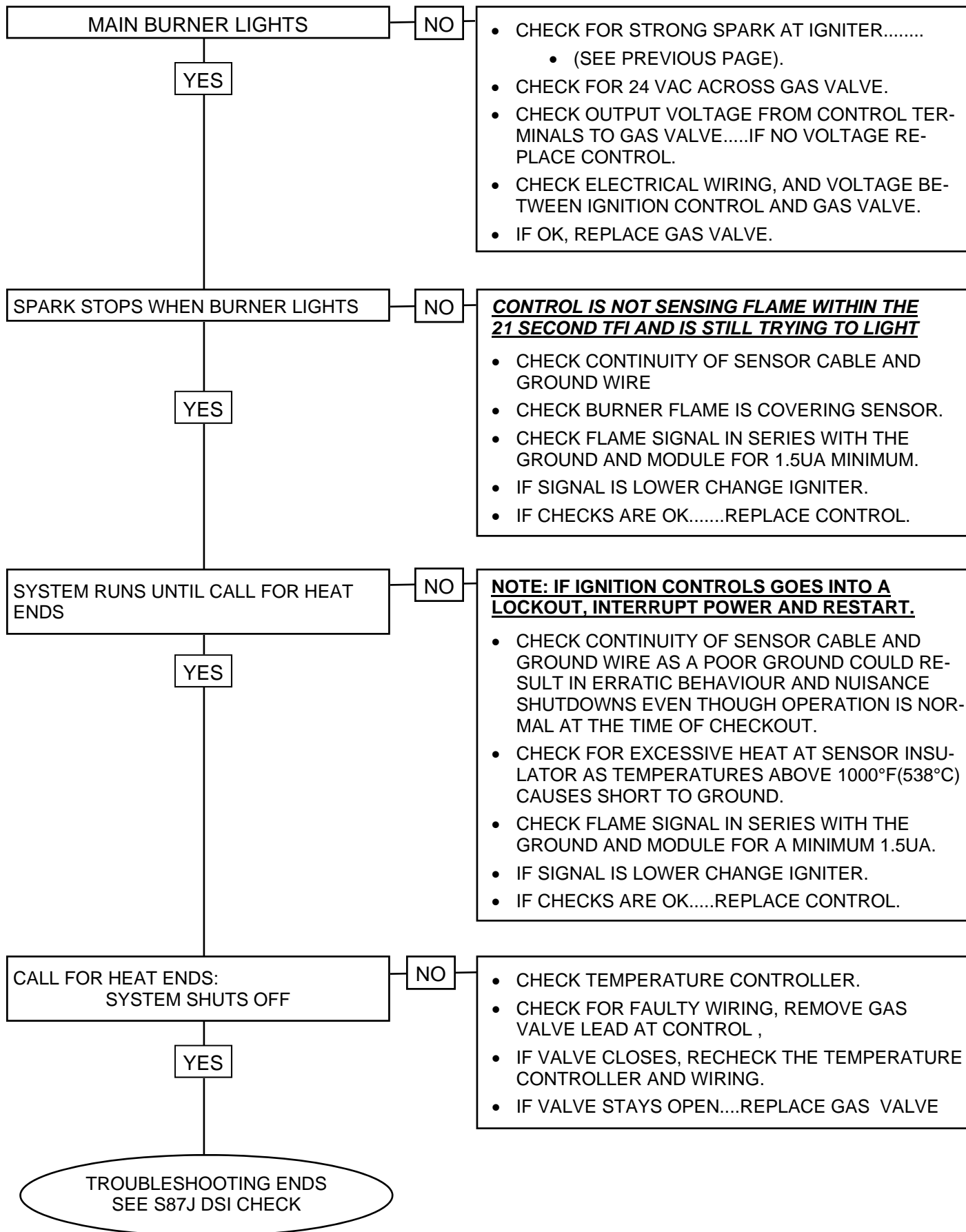

22. SPARK IGNITION CIRCUIT

The step-up transformer in the ignition control provides spark ignition at 30,000 volts (open circuit). To check the spark ignition circuit, proceed as follows.

- Shut off gas supply to the gas control
- Disconnect the ignition cable at the ignition control stud terminal to isolate the circuit from the Spark Igniter or Igniter / Sensor
- Prepare a short jumper lead, using heavily insulated wire such as ignition cable



CAUTION

In the next step, DO NOT allow fingers to touch either the stripped end of the jumper or the stud terminal. This is a very high voltage circuit and electrical shock, personal injury, or death can result.

- Perform this test immediately upon energizing the system before the Ignition Control goes into safety lockout and interrupts the spark circuit. Touch one end of the jumper firmly to the ignition control GND terminal. (DO NOT remove the existing ground lead.) Slowly move the other end of the jumper wire toward the stud terminal on the Ignition Control to establish a spark.
- Pull the wire away from the stud and note the length of gap at which spark discontinues.
- A spark length of 1/8 in. (3 mm) or more indicates satisfactory voltage output. If no arc can be established, or the maximum spark is less than 1/8 in. (3 mm), and power to the Ignition Control input terminals was proved, replace the Ignition Control.

TURN OFF THE POWER AND RECONNECT THE IGNITION WIRE TO THE IGNITION CONTROL STUD. DISCONNECT THE IGNITION WIRE FROM THE IGNITER AND REPEAT THE STEPS ABOVE BY GROUNDING THE WIRE OUT TO THE TUBE BODY THIS TIME. TURN ON THE POWER AND PULL THE WIRE AWAY FROM THE TUBE AND NOTE THE LENGTH OF GAP AT WHICH THE SPARK DISCONTINUES. IF THERE IS NO SPARK OR WEAK SPARK REPLACE THE IGNITION WIRE.

SPARK IGNITER SET UP

Use the following diagram to check the Igniter gap. If the gap is incorrect all adjustments should be made with the **GROUND PRONG/PIN ONLY! DO NOT BEND THE IGNITER PRONG!!!!**

USE THE BLACK BARS BELOW AS A GUIDE FOR ADJUSTMENT. USE THE BARS THAT COINCIDE WITH THE FORMAT & SIZE OF THIS PUBLICATION.

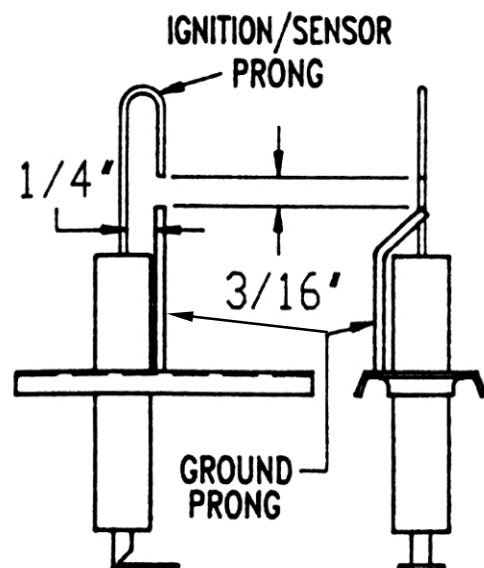
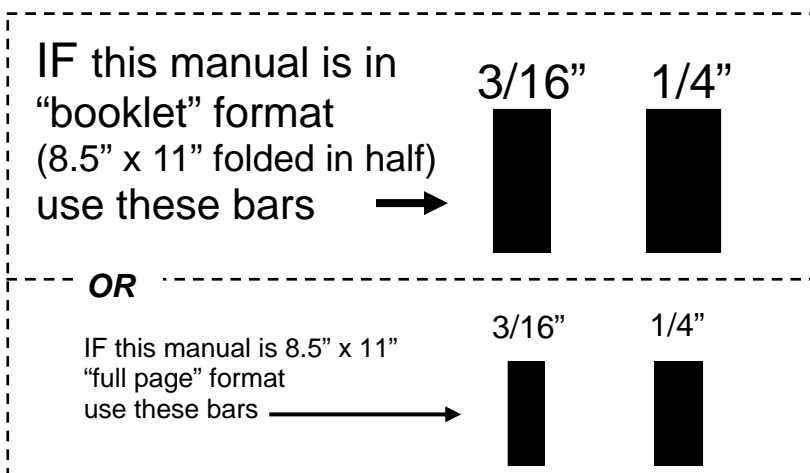

23. FLAME SENSING CIRCUIT

The output of the flame sensing circuit cannot be checked directly on the S87 body. Check the flame sensing circuit directly by checking the flame sensing current from the sensor to the S87 as follows.

1. Connect a meter (dc microammeter scale) in series with the flame signal ground wire as shown below. Using the Honeywell W136A Test Meter or equivalent. Disconnect the ground wire from the S87. Connect the red (positive) meter lead to the free end of the ground wire. Connect the black (negative) meter lead to the quick-connect ground terminal on the S87.
2. Restart the system and read the meter. The flame sensor current must be at least 1.5 uA and steady. If the reading is less than 1.5µA or unsteady, see LOW OR UNSTEADY FLAME CURRENT section, below.

If a flame is present at sensor and a reading of zero uA is obtained, check for a secondary ground connection to the 24V (GND) terminal. If secondary connection exists, temporarily remove connection and measure flame current.

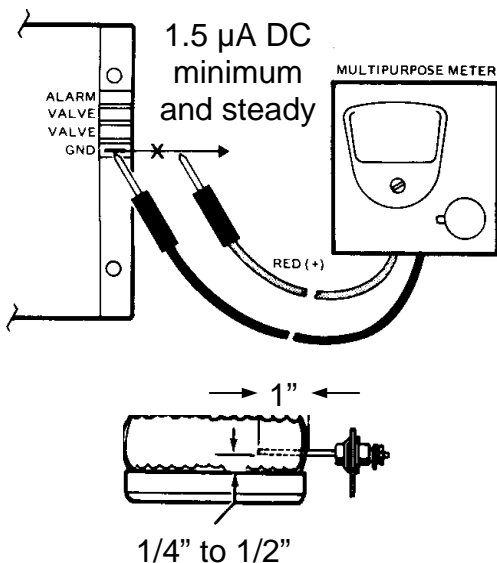

A good rectifying flame is achieved with approx 1" of sensor in a strong blue flame, positioned 1/4" to 1/2" away from flame source surface.



A lazy or weak flame is not a good rectifying flame. Check gas pressure and gas orifice for insects, and spider webs.

LOW/ UNSTEADY FLAME CURRENT

If the current to the S87 flame circuit is less than 1.5 µA or is unsteady, check the burner flame, flame sensor location and electrical connections as follows.

Electrical Connections and Shorts

Connections at the flame sensor must be clean and secure. If wiring needs replacement, use moisture resistant #18 wire rated for continuous duty up to 221⁰ F [105⁰ C].

Flame Sensor

The flame signal is best when about 1 in. [25 mm] of flame rod is immersed in the burner flame. A bent flame rod, bent mounting bracket or cracked ceramic insulator will affect flame signal.

Replace flame sensor if necessary.

Burner Flame

The flame sensor must be constantly immersed in flame. Check burner flame condition as shown opposite. Observe burner rating plate for the correct gas pressure, and check with a manometer. If gas pressure is correct check line and orifice for obstructions.

24. START-UP / COMMISSIONING SHEET



THIS EQUIPMENT HAS BEEN FACTORY FIRED AND TESTED PRIOR TO SHIPMENT. HOWEVER, THIS APPLIANCE IS NOT "PLUG & PLAY". IT REQUIRES COMMISSIONING AND FIELD ADJUSTMENT / SPECIFICATIONS CONFIRMATION TO ENSURE SAFE AND EFFICIENT OPERATION.

**COMMISSIONING REPORT
AS PER I&O MANUAL AND LOCAL CODES**

CONTRACTOR NAME:DATE.....

ADDRESS:.....
.....

CITY:.....

PHONE:.....

CELL:

JOB SITE.....CITY.....

HEATER MODEL NUMBER:.....
Located on burner rating plate

HEATER SERIAL NUMBER:

TO ENSURE THAT SITE CONDITIONS ARE COMPATIBLE WITH THE HEATER'S PERFORMANCE AND TO ALLEVIATE NUISANCE CALL-BACKS, THE FOLLOWING START-UP NEEDS TO BE COMPLETED BY THE QUALIFIED GAS INSTALLER.

A TECHNICIAN CALLING FOR TECHNICAL SUPPORT MUST PROVIDE THE INFORMATION FROM THE COMPLETED COMMISSIONING REPORT ON THE NEXT PAGE

**FAX COMPLETED REPORT TO TECHNICAL SERVICES:
FAX 1-866-361-0523,
VOICE 1-877-446-3727**



START UP 'SMOKE'

During start up, material coatings used in the production process of tubes and reflectors will "burn off" and create smoke during the first hour of operation. This is temporary and normal. Please ensure that there is sufficient ventilation to adequately clear the smoke from the space. Notify site and safety personnel to ensure that alarm systems are not unduly activated.

**QUALIFIED INSTALLER TO COMPLETE THIS
TUBE HEATER COMMISSIONING REPORT**

TYPE OF GAS: NG LP

DOES BUILDING HAVE A NEGATIVE CONDITION: YES NO

IF THIS IS A HIGH ALTITUDE AREA WHAT IS THE ALTITUDE ABOVE SEA LEVEL Ft

DOES APPLICATION REQUIRE FRESH AIR TO BURNER YES NO

IS HEATER EXPOSED TO CHEMICAL OR CORROSIVE ATMOSPHERE: YES NO

ARE ACTUAL MINIMUM CLEARANCES AS PER TABLE 3 YES NO

CAN HEATER BE AFFECTED BY OVERHEAD CRANES / VIBRATION YES NO

ARE GAS SUPPLY LINES ADEQUATELY SIZED FOR SYSTEM YES NO

GAS LINES AND BRANCHES HAVE BEEN PURGED OF AIR: YES NO

THIS HEATER FIRED WITHOUT ANY MALFUNCTION: YES NO

INLET GAS SUPPLY PRESSURE WITH HEATER OPERATING : WC"

GAS VALVE OUTLET (Manifold) PRESSURE WITH HEATER OPERATING: WC"

WHAT IS THE LINE VOLTAGE READING AT THE HEATER VOLTS

WHAT IS THE VOLTAGE READING AT THE IGNITION MODULE VOLTS

WHAT IS THE FLAME SIGNAL STRENGTH IN uA FROM SENSOR: uA (microamps)

IS HEATER CONTROLLED BY A THERMOSTAT YES NO

IS THE THERMOSTAT STRATEGICALLY LOCATED YES NO

WHAT IS TOTAL LENGTH OF INSTALLED THERMOSTAT WIRE FEET

WHAT IS THE GAUGE OF THE THERMOSTAT WIRE GAUGE

WHAT IS THE HEATER TUBE LENGTH (10ft per Tube section) FEET

WHAT IS THE TOTAL LENGTH OF THE VENT (add 10ft for each bend) FEET

WHAT LENGTH IS COMBUSTION AIR INTAKE (add 10ft for each bend) FEET

IF REQUIRED....WHAT IS THE LENGTH OF THE TURBULATOR(S) FEET

IF INSTALLED....IS TURBULATOR AT FLUE END OF SYSTEM YES NO

"MAXIMUM STACKING HEIGHT" SIGN(S) - POSTED AT THERMOSTAT(S)

THIS HEATER MUST BE ELECTRICALLY GOUNDED

FAX COMPLETED REPORT TO TECHNICAL SERVICES: FAX 1-866-361-0523, VOICE 1-877-446-3727

25. BTUH INPUT RATINGS AND CORRESPONDING DIMENSIONS

| BTUH INPUT 0' TO 4500' ABOVE SEA LEVEL | NOMINAL LENGTH (FT) | OVERALL HEATER LENGTH* (FT) | APPROX NET WEIGHT** (LBS) |
|--|---------------------------|--------------------------------|------------------------------|
| 60,000 | 30 | 31' | 154 |
| 60,000 | 20 | 21' 4" | 111 |
| 45,000 | 20 | 21' 4" | 111 |
| 45,000 | 10 | 11' 8" | 68 |

- Manufactured and shipped in 10 ft lengths.
- Swaged tube has approximate 4 inch (10 cm) overlap -
 - Net length of first and intermediate tubes is 116 inches (295 cm)
 - Last tube is 120" (305 cm) [the 4 inch swage length is exposed for vent connection]
 - Total tube length is approximately 4 inches (10 cm) shorter for each multiple of 10 feet (305 cm)
 - Overall length of heater includes the burner.

** Burner weight is 26 pounds (11.8 kg)
 Each 10 ft (305 cm) tube/reflector section weighs 82 pounds (37.2 kg)

FIGURE 21 BURNER DIMENSIONS

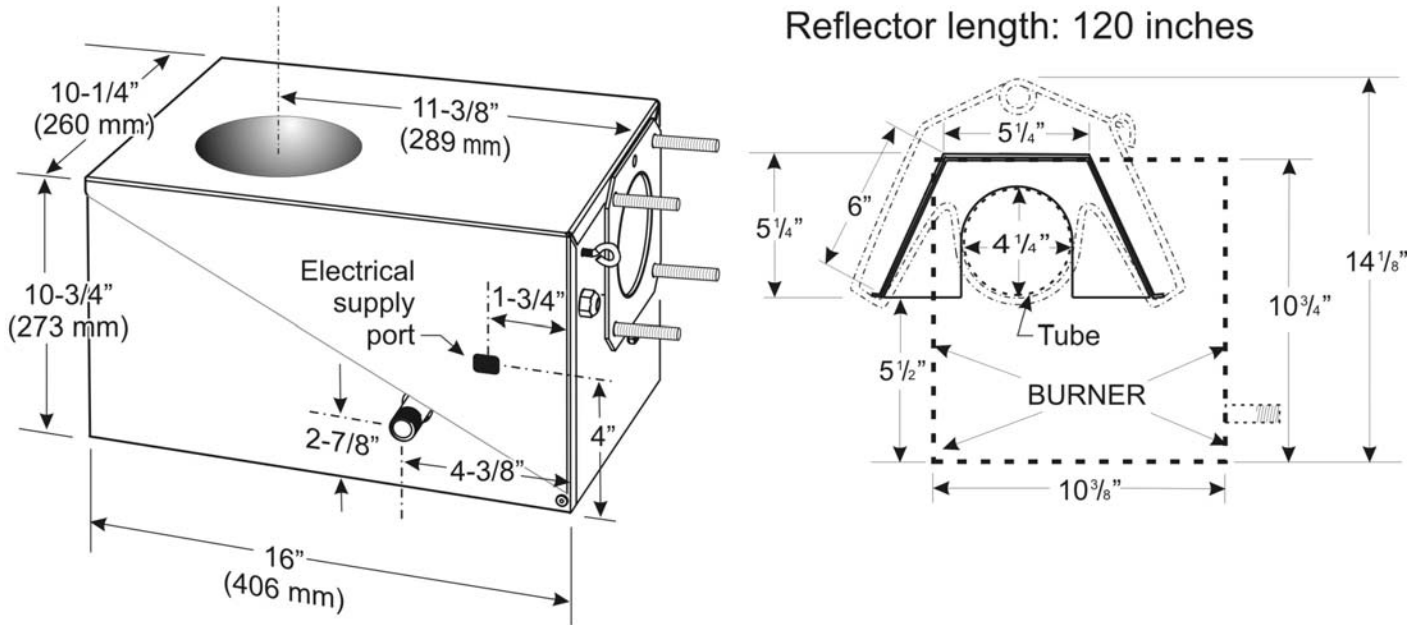
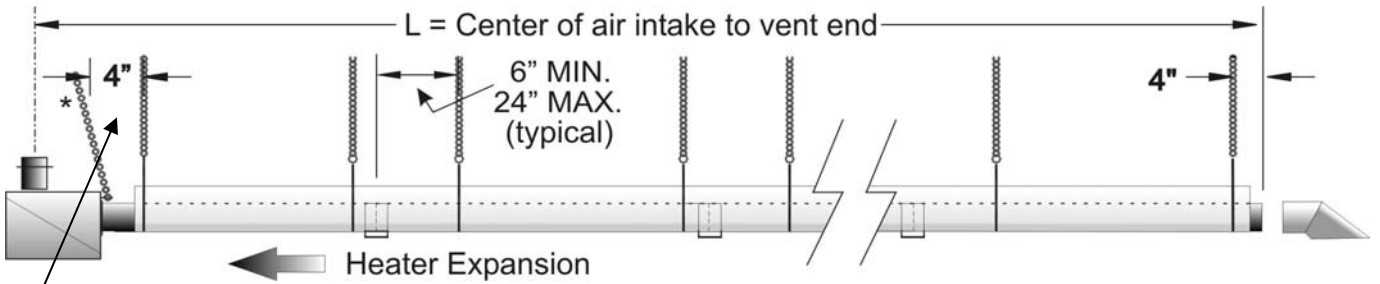

FIGURE 22 HANGER SPACING / LENGTH - AIR INTAKE TO VENT END



- POSITION BURNER END HANGER 4 INCHES (10 CM) FROM BURNER
- LOCATE SYSTEM HANGERS NO LESS THAN 6 INCHES (15 CM) AND NO MORE THAN 24 INCHES (61 CM) FROM TUBE COUPLING
- * ANGLE BURNER SUPPORT CHAIN BACK OVER BURNER - ALLOWS TUBE SYSTEM EXPANSION

| Length | Tube 'L' = center air intake to end |
|--------|--|
| 10' | 11'-3 3/4" ; 135 3/4" ; 345 cm |
| 20' | 20'-11 3/4" ; 251 3/4" ; 628 cm |
| 30' | 30'-7 3/4" ; 367 3/4" ; 934 cm |

26A. BURNER & TUBE KIT ASSEMBLY CHART MODELS IRB

MODELS IRB is approved for indoor residential applications.



BEFORE INSTALLING: ENSURE you have the CORRECT TUBE KIT(s) for the BURNER INPUT

BURNER & TUBE KIT ASSEMBLY CHART

MODEL: **IRB:**

Residential Garage/Workshop Heaters

| BURNER KIT FIRING RATE | | TUBE KIT PART # & QUANTITY REQUIRED | | | |
|---------------------------|-------|--|--------------------|--------------------|----------------------|
| | | Stand-Alone Kits <u>Only</u> | | | |
| | | TM- 4510- SX | TM- 1420- SX | TM- 1430- SX | TM- 1410- SU** |
| 45,000 | 10' | 1 | | | |
| | 20' | | 1 | | |
| 60,000 | 20' | | 1 | | |
| | 30' | | | 1 | |
| | 10' U | | | | 1 |

FLEXIBLE GAS CONNECTOR (Included in Burner Kit) - MUST INSTALL - see Section 13

USA - Stainless Steel Flexible Gas Connector

130,000 or less:
JL-0771-XX - 1/2"x24"

155,000 or more:
JL-0771-YY - 3/4"x36"

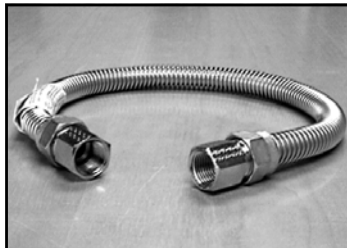

CANADA - Type 1 Hose Gas Connector

130,000 or less:
JL-0771-RC - 1/2"x36"

155,000 or more:
JL-0771-RB - 3/4"x36"



27. TURBULATORS:



NOTE: Improper location of a turbulator can cause malfunction of the heater, property damage, and will void the heater warranty.

Tube Heaters are supplied with all required turbulator(s) factory installed into the tube(s). Tubes with turbulators are installed at the vent end of the system configuration and are clearly labeled for easy identification.

| MODEL | TURBULATOR LENGTH |
|-----------|-------------------|
| IRB 60-30 | 14' (4.3 m) |
| IRB 60-20 | 14' (4.3 m) |
| IRB 45-20 | 14' (4.3 m) |
| IRB 45-10 | 5' (1.5 m) |

| MODEL | TURBULATOR LENGTH |
|-------------|-------------------|
| IRBU 60-10U | 14' (4.3 m) |

28. HIGH ALTITUDE INSTALLATION

When this appliance is installed above the altitude stipulated below, the input must be de-rated by 4% for each 1000 ft . **If your local utility supplies gas with a de-rated heat content, no orifice change is required in the heater** . Check with your local utility regarding de-rating.

USA: The factory installed orifice for this appliance is approved for altitudes zero to 2000 feet above sea level. Above 2000 feet, refer to table below.

Canada: The factory installed orifice for this appliance is approved for altitudes zero to 4500 feet above sea level. When installed above 4500 feet, refer to the table below.

~ ORIFICE TABLE NEXT PAGE ~



28. **HIGH ALTITUDE INSTALLATION** *continued*

ORIFICE CHART - ALTITUDE CONVERSION





~ SEE NOTES ON PREVIOUS PAGE ~

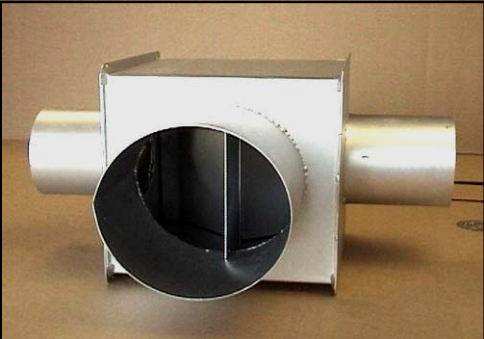

| MODEL NO | FOR USE AT ALTITUDES ABOVE (FEET) Gas Orifice Drill Size / Part# | | | | | | | |
|-------------------|---|----------------------|----------------------|----------------------|----------------------|----------------------|----------------------|----------------------|
| | Supplied | USA Only | | | USA & CANADA* | | | |
| | 0 | 2000 | 3000 | 4000 | 5000 | 6000 | 7000 | 8000 |
| IRB-45 NG | 29 DMS JS-0729-DM | 29 DMS JS-0729-DM | 30DMS JS-0730-DM | 30DMS JS-0730-DM | 30DMS JS-0730-DM | 30DMS JS-0730-DM | 31DMS JS-0731-DM | 31DMS JS-0731-DM |
| IRB-45 LPG | 46 DMS JS-0746-DM | 46 DMS JS-0746-DM | 46 DMS JS-0746-DM | 48 DMS JS-0748-DM | 48 DMS JS-0748-DM | 48 DMS JS-0748-DM | 49 DMS JS-0749-DM | 49 DMS JS-0749-DM |
| IRB-60 NG | 25 DMS JS-0725-DM | 26 DMS JS-0726-DM | 27 DMS JS-0727-DM | 27 DMS JS-0727-DM | 28 DMS JS-0728-DM | 28 DMS JS-0728-DM | 29 DMS JS-0729-DM | 29 DMS JS-0729-DM |
| IRB-60 LPG | 42 DMS JS-0742-DM | 42 DMS JS-0742-DM | 43 DMS JS-0743-DM | 43 DMS JS-0743-DM | 43 DMS JS-0743-DM | 44 DMS JS-0744-DM | 44 DMS JS-0744-DM | 45 DMS JS-0745-DM |

29. OPTIONAL ACCESSORIES

| | | |
|---|-------------------------------------|--|
| <p>#2 Lion Chain (115 lb work load) - 200 ft roll</p> <p>'S' Hooks - 1 7/8" - package of 25</p> | <p>JL-0800-XX</p> <p>JL-0798-SH</p> |  |
| <p>Flue Vent Terminal</p> <p>4" wall horizontal</p> <p>6" wall horizontal</p> | <p>JA-0528-XX</p> <p>JA-0529-XX</p> |  |
| <p>Torcrite Coupler</p> <p>Sufficient quantity supplied with heater</p> <p>Use for connection of vent tee, or replacement part</p> | <p>JA-0516-SW</p> |  |
| <p>Vent Tee 4" X 4" X 6"</p> <p>(Couplers optional - see above)</p> | <p>JA- 0514-XX</p> |  |

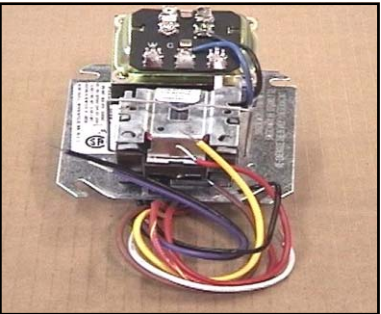
| | | |
|--|----------------------------------|---|
| <p>Fresh Air Intake Adapter</p> | <p>JS-0532-SE</p> |  |
| <p>Fresh Air Intake Cap—Wall</p> | <p>JS-0532-VC</p> |  |
| <p>Fresh Air Intake Cap—Roof</p> <p>4" roof cap 6" roof cap</p> | <p>JA-0530-XX JA-0531-XX</p> |  |

| | | |
|--|--------------------|---|
| <p>Low Voltage Digital Thermostat (24 Volts - °F or °C selectable) <i>Not for use in corrosive or wet environments</i></p> | <p>JS-0569-WR</p> |  |
| <p>TruTemp Thermostat True comfort control for radiant heating systems - senses and averages ambient and radiant temperatures. Occupancy sensor with auto set-back of 9°F (5°C). <i>Do not use in wet or corrosive environments</i></p> | <p>JM-0150-XX</p> |  |
| <p>Line Voltage Thermostat: Dual Scale: °F or °C <i>Not for use in corrosive or wet environments</i></p> | <p>JL-0772-XX</p> |  |
| <p><u>Required For 24V Thermostat Control:</u></p> | | |
| <p>Relay Kit <u>Single Heater</u> per 24V Thermostat (field installed in burner)</p> | <p>JS-0568-KT</p> |  |
| <p>24 Volt Option: Control Center <u>Multiple Tube Heaters</u> controlled by a single TruTemp or 24V Thermostat (field installed)</p> | <p>JM-0303 -KT</p> |  |

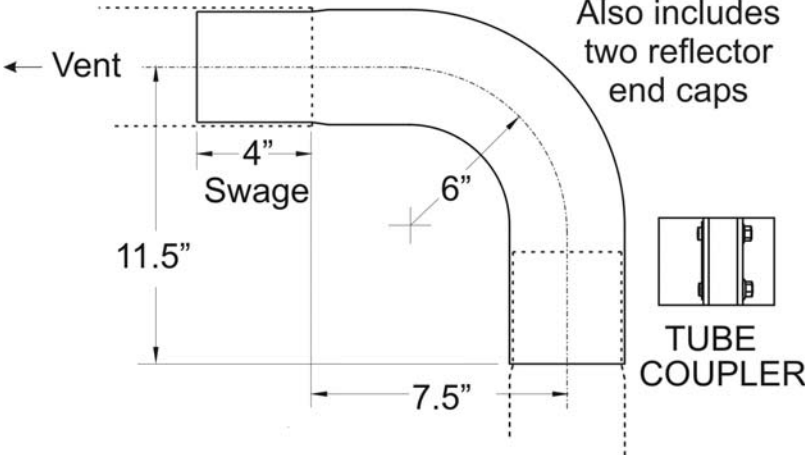
| | | |
|---|--|---|
| <p>90 degree Aluminized Steel Elbow Kit</p> <p>(Kit includes: aluminized steel elbow, coupler, and two end plate hangers)</p> <p>For 180° elbow use two x JS-0508-SM, or use Model S100U / ITBU</p> | <p>JS-0508-SM</p> |  |
| <p>Side Reflector Extension Kit- 10" deep, 10 ft long Each</p> | <p>JS-0509-KT</p> |  |
| <p>Tube Protection Screen -5 foot lengths</p> | <p>JA-0780-XS <i>For Builder Model</i></p> |  |
| <p style="text-align: center;">90° Elbow Kit JS-0508-SM</p> <p style="text-align: right;">Also includes two reflector end caps</p>  | | |

30 REPLACEMENT PARTS

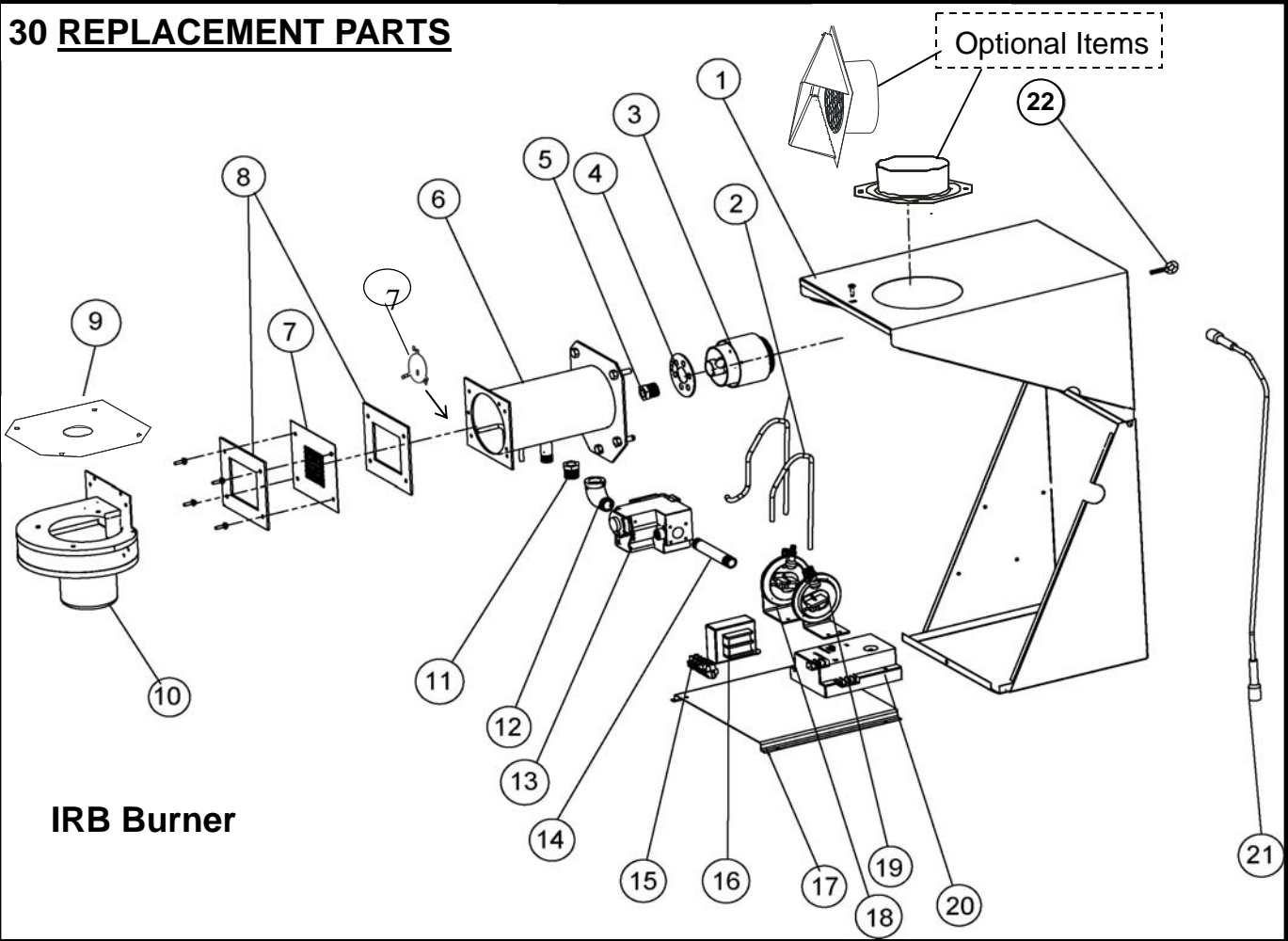

IRB Burner

| # | PART DESCRIPTION | PART # | PART DESCRIPTION PRIMARY | SUPPLEMENT |
|---|------------------------|---|--|---------------|
| 1 | BURNER HOUSING | JS-0582-XX | Burner housing coated orange | Schwank |
| | | JJ-0582-XX | Burner housing coated gray | InfraSave |
| 2 | PRESSURE SWITCH TUBING | JS-0572-SE | Tubing set 2 x 20" PVC SE | |
| 3 | BURNER HEAD | JS-0510-LP-45 | Burner head 45 Mbh | 45 |
| | | JS-0510-LP | Burner head 60, 80, 100 | 60-100 |
| | | JS-0512-XX | Burner head large | 110-200 |
| 4 | AIR RESTRICTOR RING | JS-0596-AA | Burner head air restr ring 9/32" | 45LP, NG |
| | | JS-0596-XX | Burner head air rest ring 0.375 | 60LP,60-200NG |
| | | JS-0597-XX | Burner head air rest ring 0.500 | 80-200LP |
| 5 | MAIN BURNER ORIFICE | JS-0748-DM | Gas orifice low intensity HR 48 DMS | 45 LP |
| | | JS-0730-DM | Gas orifice low intensity HR 30 DMS | 45 NG |
| | | JS-0742-DM | Gas orifice low intensity HR 42 DMS | 60 LP |
| | | JS-0725-DM | Gas orifice low intensity HR 25 DMS | 60 NG |
| | | JS-0736-DM | Gas orifice low intensity HR 36 DMS | 80 LP |
| | | JS-0718-DM | Gas orifice low intensity HR 18 DMS | 80 NG |
| | | JS-0731-DM | Gas orifice low intensity HR 31 DMS | 100, 110 LP |
| | | JS-0752-MM | Gas orifice low intensity HR 5.2 mm | 100, 110 NG |
| | | JS-0729-DM | Gas orifice low intensity HR 29 DMS | 130 LP |
| | | JS-0758-MM | Gas orifice low intensity HR 5.8 mm | 130 NG |
| | | JS-0714-IN | Gas orifice low intensity HR 9/64 inch | 155 LP |
| | | JS-0725-IN | Gas orifice low intensity HR 1/4 inch | 155 NG |
| | | JS-0721-DM | Gas orifice low intensity HR 21 DMS | 175 LP |
| | | JS-0767-MM | Gas orifice low intensity HR 6.7 mm | 175 NG |
| | | JS-0719-DM | Gas orifice low intensity HR 19 DMS | 200 LP |
| | JS-0730-IN | Gas orifice low intensity HR 19/64 inch | 200 NG | |

| # | PART DESCRIPTION | PART # | PART DESCRIPTION PRIMARY | SUPPLEMENT |
|-------------------|----------------------------------|-----------------------------|---|------------------|
| 6 | OUTER BURNER | JS-0504-XX | Outer burner assy | |
| 7 | EQUALIZER PLATE | JS-0593-XL | Outlet equalizer plate 45 LP - 29 Holes | 45-LP |
| | | JS-0593-NG | Outlet equalizer plate 45 NG - 25 Holes | 45-NG |
| | | JS-0593-XX | Outlet equalizer plate 60 to 200 | 60 - 200 |
| 7A | BURNER AIR RESTRICTOR | JS-0592-AR | Burner air restrictor (45 Only) | 45 |
| 8 | BLOWER GASKET | JS-0578-XX | Outlet blower gasket | each |
| 9 | AIR INLET C/W SCREEN | JS-0595-AC | S100/ ITB 45 NG blower ring c/w 1/2" bird screen | 45 NG |
| | | JS-0594-ET | S100/ ITB 45 LP, 60 blower ring c/w 1/2" bird screen | 45 LP, 60 |
| | | JS-0595-EP | S100/ ITB 80, 100NG blower ring c/w 1/2" bird screen | 80, 100NG |
| | | JS-0595-EA | S100/ ITB 100LP, 110-200 blower ring c/w 1/2" bird screen | 100LP, 110-200 |
| 10 | BLOWER | JS-0579-AA | Blower assy tube burner | |
| 11 | MANIFOLD BUSHING | JM-0589-XX | Manifold bushing | |
| 12 | 90 DEGREE ELBOW FITTING 1/2" | JS-0588-XX | Street elbow fitting 90 deg | |
| 13 | GAS VALVE | JL-0701-AA | Valve gas comb 3.5" WC 24VAC VR8 NG | |
| | | JL-0703-AA | Valve gas comb 10" WC 24VAC VR8 LP | |
| 14 | 4" NIPPLE | JS-0590-XX | Nipple 4" | |
| 15 | TERMINAL BLOCK | JM-0455-DD | Terminal block | |
| 16 | STEP DOWN TRANSFORMER | JA-0775-XX | Transformer 120/24V, 20VA AT120B1028 | |
| 17 | COMPONENT PLATE | JS-0581-XX | Component mounting plate SE | |
| 18 | COMBUSTION AIR PROVING SWITCH | JS-0576-XX | Switch air proving 0.48" WC | 80 |
| | | JS-0576-YY | Switch air proving 0.30" WC | 60 |
| | | JS-0575-YY | Switch air proving 0.65" WC | 110-155 |
| | | JS-0576-AA | Switch air proving 0.85" WC | 45, 100, 175-200 |
| 19 | BLOCKED FLUE PROVING SWITCH | JS-0577-ZZ | Switch flue blocked 1.41" WC | 100, 175-200 |
| | | JS-0577-SS | Switch flue blocked 0.58" WC | 60 |
| | | JS-0577-YY | Switch flue blocked 0.90" WC | 45, 80-155 |
| 20 | IGNITION CONTROL | JA-0568-XX | Control DSI 24VAC S87J-1034 | |
| | Replacement Kit | JA-0568-KT | DSI S87J + CABLE + IGNITER KIT | |
| 21 | IGNITION CABLE | JS-0518-XX | Wire high voltage (24") | |
| 22 | EYE BOLT | JF-1012-EB | Eye Bolt | |
| | COMBUSTION AIR INTAKE ADAPTER 4" | JS-0532-VC | Fresh air intake adapter 4" (Mounts to top of cabinet) | OPTIONAL |
| | COMBUSTION AIR INLET WALL CAP 4" | JS-0532-VC | Fresh air intake horizontal (wall) vent cap 4" | OPTIONAL |
| NOT SHOWN: | | | | |
| | ROOF CAP 4" | JA-0530-XX | 4" Roof Cap - Vent or Combustion Air Intake | OPTIONAL |
| | HORIZONTAL FLUE VENT TERMINAL 4" | JA-0528-XX | 4" Through Wall Vent Terminal | OPTIONAL |
| | COMPLETE BURNER KIT | Refer to Current Price List | | |

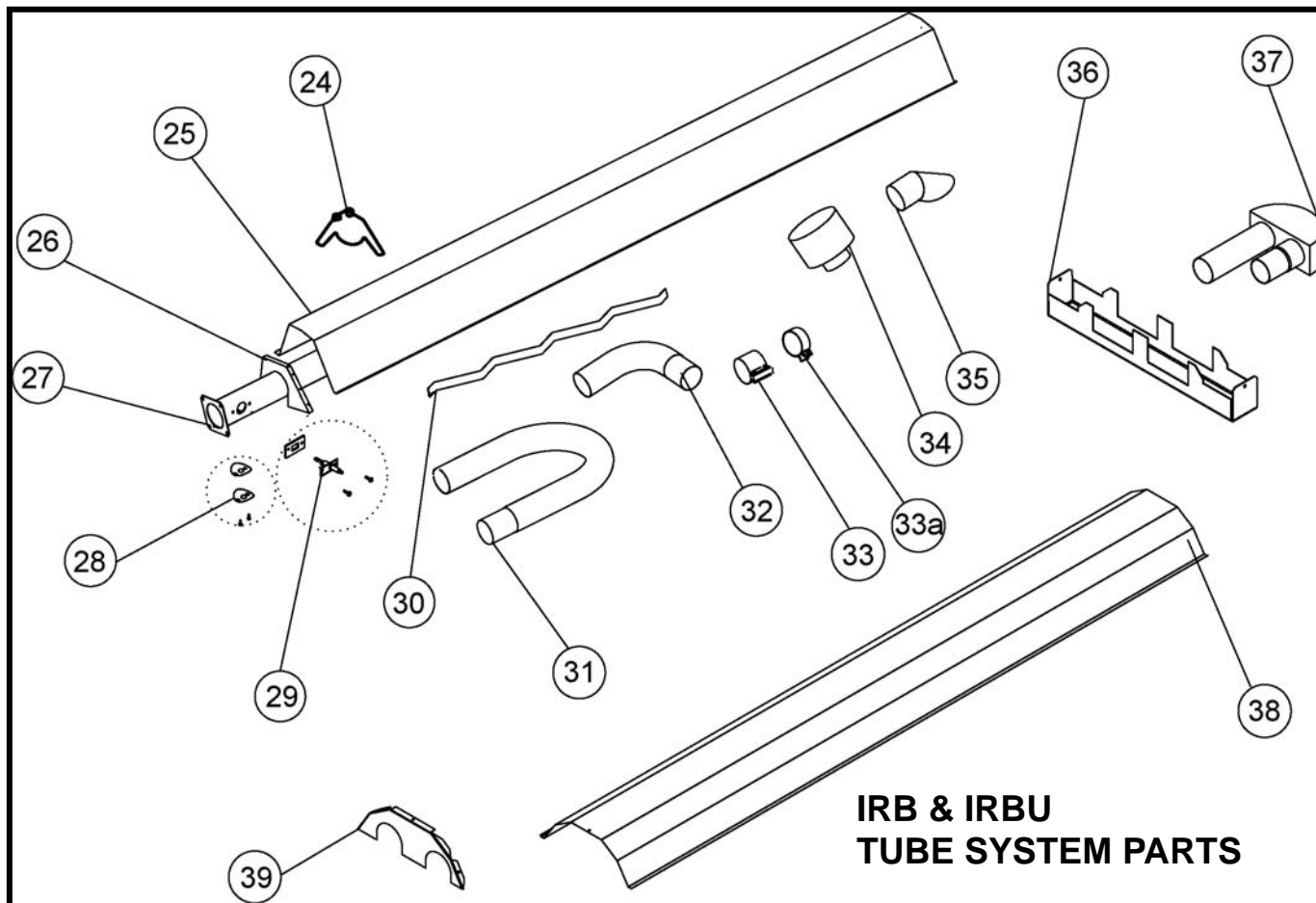

| # | PART DESCRIPTION | PART # | PART DESCRIPTION PRIMARY | SUPPLEMENT |
|-----|------------------------------------|-----------------------------|---|-----------------|
| 24 | WIRE HANGER | JS-0505-EH | Small wire hanger | |
| 25 | REFLECTOR | JS-0502-EM | Reflector (18" x 120") | |
| 26 | END CAP | JS-0502-ES | S100 / ITB series reflector end cap | |
| 27 | LOW INTENSITY TUBE | JS-0501-SW-P | Aluminized tube,flanged,swaged c/w ports | 60-155 |
| | | JS-0501-SK | Aluminized tube, 10' slotted + Accuseal clamp | 175-200 |
| | | JS-0499-SW-P | Alumatherm tube,flanged,swaged c/w ports | 175-200 |
| | | JS-0515-SW-P | Steel tube 10' swaged | |
| | | JS-0515-SW-5 | Steel tube 5' swaged | |
| 28 | SIGHT GLASS ASSEMBLY | JS-0536-XX | Sight glass assembly tube heater | |
| 29 | IGNITER KIT | JA-0571-KT | Igniter & gasket kit / DSI tube heater | |
| 30 | TURBULATOR (see Table 4 in Manual) | JS-0534-SS | Turbulator 5' (7 PLATE) | 45 x 10 ft ONLY |
| | | JS-0533-SH | Short turbulator 4' | |
| | | JS-0533-LG | Turbulator 10' | |
| 31 | ELBOW 4" | JA-0508-SW | 90 degree elbow | |
| 32 | ELBOW 4" | JA-0513-SW | 180 degree elbow | |
| 33 | COUPLER | JA-0516-SW | 4" swaged tube coupler torctite | |
| 33a | COUPLER 175 & 200 Mbh | JA-0516-RK | Coupler 4" with Rivet & Drill Bit | 175-200 |
| 34 | VENT CAP | JA-0530-XX | 4" roof vent cap | |
| 35 | VENT CAP | JA-0528-XX | 4" horizontal wall vent terminal | |
| 36 | DOUBLE STEEL HANGER | JS-0505-BU | U tube reflector hanger | |
| 37 | TURN BOX | JS-0513-BU | U tube turn around box | |
| 38 | DOUBLE REFLECTOR | JS-0502-BU | Wide reflector 24" x 120" | |
| | | JS-0502-BU5 | Wide reflector 24" x 60" | |
| 39 | U REFLECTOR END CAP | JS-0502-ND | S100 / ITB series "U" reflector end cap | |
| | COMPLETE TUBE KITS | Refer to Current Price List | | |



FOR GAS-FIRED INFRA-RED LOW INTENSITY TUBE HEATERS: IRB / IRBU SERIES

The Manufacturer warrants that this product is free from defects in material or workmanship under normal use and service subject to the terms of this document.

TWO YEAR WARRANTY

Subject to the conditions and limitations stated herein, during the term of this limited warranty, we will supply any component part (at our option a new or repaired component part) of the heater as defined below, excluding any labor, which the Manufacturer's examination determines to be defective in workmanship or material for a period of two years (2 years) from the date of installation, unless otherwise specified below. This warranty applies to the heater's original owner, and subsequent transferees and only if the unit is installed and operated in accordance with the printed instructions accompanying the unit and in compliance with all applicable installation codes and good trade practices. Warranty is only applicable to Schwank components, other parts are limited to their own Manufacturers warranty period of one year (1 year).

FIVE YEAR WARRANTY

The Manufacturer warrants the burner sub-assembly comprising of ceramic and immediate metal tubing, and the radiating tubes (excluding couplings) for a period of five years (5 years).

WHAT IS NOT COVERED

The Manufacturer shall not be responsible for any expenses, including service, labor, diagnosis, analysis, material or transportation charges incurred during removal or reinstallation of this product, or any of its components or parts. All labor or service charges shall be paid by the owner. This warranty does not cover heating products improperly installed, misused, exposed to or damaged by negligence, accident, corrosive or contaminating atmosphere, water, excessive thermal shock, impact, abrasion, normal wear due to use, alteration or operation contrary to the owner's manual or if the serial number has been altered, defaced or removed. This warranty shall not apply if the input to the heating product exceeds by more than 2% of the rated input on the rating plate. The Manufacturer shall not be liable for any default or delay in performance by its warranty caused by any contingency beyond its control, including war, government restrictions, or restraints, strikes, fire, flood, acts of God, or short or reduced supply of raw materials or products.

WARRANTY PROCEDURE

To establish the installation date for any purpose under this Limited Warranty, you must retain the original records that can establish the installation date of your unit. If you do not provide such documents, the start date of the term of this Limited Warranty will be based upon the date of unit manufacture, plus thirty (30) days. Failure to maintain the equipment through regular annual service maintenance by a qualified service technician shall void the warranty.

LIMITATIONS AND EXCLUSIONS

This document contains all warranties made by the Manufacturer and may not be varied, altered or extended by any person. There are no promises, or agreements extending from the Manufacture other than the statements contained herein. THIS WARRANTY IS IN LIEU OF ALL WARRANTIES EXPRESSED OR IMPLIED, TO THE EXTENT AUTHORIZED BY THE LAWS OF THE JURISDICTION, INCLUDING SPECIFICALLY THE WARRANTIES OR MERCHANTABILITY OF FITNESS FOR A PARTICULAR PURPOSE.

It is understood and agreed that the Manufacturer's obligation hereunder is limited to repairing or replacing parts determined to be defective as stated above. In no event shall the Manufacturer be responsible for any alleged personal injuries or other special, incidental or consequential damages. As to property damages, contract, tort or other claim the Manufacturer's responsibility shall not exceed the purchase priced paid for the product.

All replacement parts will be warranted for the unused portion of the warranty coverage period remaining on the applicable unit.

Some Authorities do not allow certain warranty exclusions or limitations on duration of warranty or the exclusions or limitations of incidental or consequential damages. In such cases, the above limitations or exclusions may not apply to you and are not intended to do so where prohibited by law. This warranty gives you specific legal rights. You may also have other rights which vary by jurisdiction.

SCHWANK GROUP
2 SCHWANK WAY, WAYNESBORO, GEORGIA. 30830
5285 BRADCO BLVD. MISSISSAUGA, ON, L4W 2A6

Ph: 1-877-446-3727
www.SchwankGroup.com

Fax: 1-866-361-0523
www.InfraSave.com